



Product catalogue

Model RTAC Air-Cooled Series R® Rotary Liquid Chiller

RTAC Plus 140 - 350 Ton (60 Hz)

RTAC Plus 140 - 300 Ton (50 Hz)

Built For the Industrial and Commercial Markets





Introduction

You...

Like its chillers, Trane wants its relationships with customers to last. Trane is interested in maintaining long term, loyal relationships. This perspective means the point in time that a customer purchases a chiller is the beginning of a relationship, not the end. Your business is important, but your satisfaction is paramount.

Designed by Customers....

Trane's RTAC was designed with the end user's requirements in mind. Reliability, sound, efficiency and physical size were primary design concerns with this latest generation machine. New technologies were applied to literally every major component. The result is an unparalleled engineering achievement in chiller design and manufacturing.

What's New

The RTAC offers the same high reliability of Trane's previous air-cooled helical rotary design coupled with lowered sound levels, increased energy efficiency, reduced physical footprint due to its advanced design, low speed/direct drive compressor and proven Series R® performance.

Some of the major advantages of the Model RTAC are:

- Lower sound levels
- Higher energy efficiency
- Smaller physical footprint
- HFC-134a optimized design

The Series R® Model RTAC is an industrial grade design built for both the industrial and commercial markets. It is ideal for schools, hospitals, retailers, office buildings, Internet service providers and manufacturing facilities.

Fig. 01 - Cutaway of RTAC air-cooled chiller

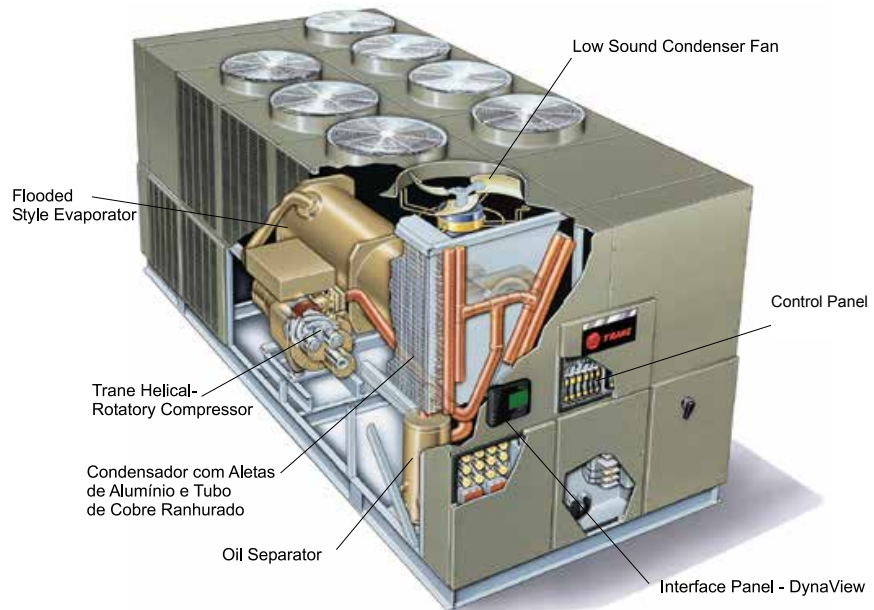

Precautions against product corrosion

It is recommended that air conditioning equipment shall not be installed in environments with a corrosive atmosphere such as acid or alkali gases and environments with a sea breeze.

In need of installing air conditioning equipment in these areas, Trane of Brazil recommends the application of extra protection against corrosion, such as Phenolic protection or the application of ADSIL.

For more information, contact your local distributor.

IMPORTANT:

Dimensional measuring units on this catalog are on milimetres (mm). (Except for those locally referenced).



Contents

Introduction	2
Model Number	4
Features and Benefits	5
Additional Information	9
Application Considerations	10
General Data	15
Selection Procedure	19
Performance Data	20
Electrical Data	34
Dimension Data	36
Wiring Diagram	44
Controls	50
Mechanical Specifications	54
Weights	55
Standard Conversion Table	57



Model Number

R	T	A	C	3	5	0	J	B	A	0	N	N	0	F	N	N	A	T	Y	2	N	D	C	N	N	0	N	N	1	0	N	N	0	P	N	N	0	0	0	0	N
1	2	3	4	5	6	7	8	9	10	11	12	13	14	15	16	17	18	19	20	21	22	23	24	25	26	27	28	29	30	31	32	33	34	35	36	37	38	39	40	41	42

Digits 1, 2 - Unit Model

RT = "Rotary Chiller"

Digit 3 - Unit Type

A = Air Cooled

Digit 4 - Project Sequence

C = Sequence C

Digits 5, 6 e 7 - Nominal Capacity

140 = 140 Nominal Tons

155 = 155 Nominal Tons

170 = 170 Nominal Tons

185 = 185 Nominal Tons

200 = 200 Nominal Tons

225 = 225 Nominal Tons

250 = 250 Nominal Tons

275 = 275 Nominal Tons

300 = 300 Nominal Tons

350 = 350 Nominal Tons

Digit 8 - Power Supply

C = 230/60/3

J = 380/60/3

D = 380-400/50/3

4 = 440-460/60/3

Digit 9 - Manufacturing Location

B = Curitiba Unit - Brazil

Digits 10, 11 - Minor Design Sequence

A0 - Sequence A0 (Factory Defined)

Digit 12 - Unit Basic Configuration

N = Standard efficiency/performance configuration

H = High efficiency/performance configuration

Digit 13 - Agency Listing

N = no agency listing

Digit 14 - Pressure vessel code

0 = no codification

Digit 15 - Evaporator Temperature Range

F = Standard (40-60°F)

G = Low Temp. (less than 40°F)

Digit 16 - Evaporator Config

N = Standard

Digit 17 - Condenser application

N = Standard Temp. (25-115°F)

L = Low Temp (0-115°F)

Digit 18 - Condensador Fin Material

A = Aluminun Standard

Y = Aluminum Yellow Fin

Digit 19 - Condenser Fan/Motor Configuration

T = Standard Fan with IPW55/TEAO motor

W = Low Noise Fans

Digit 20 - Compressor Starter Type

Y = Y-delta closed transition starter

Digit 21 - Incoming Power Line Connection

1 = Single point power connection

2 = Dual point power connection

Digit 22 - Power line connection type

N = Input power bar

D = Non-fused disconnect switch for incoming line

C = Circuit breacker for incoming line

Digit 23 - Unit operator interface

D = Dynaview

P = With protection box Dynaview

Digit 24 - Remote operator interface

N = w/o remote operator interface

C = Tracer Comm3 Interface

L = Comm5 - LonTalk Compatible (LCI-C) Interface

Digit 25 - Input Controls

N = w/o control

R = Ext. evaporator leaving water setpoint

C = Current Demand Control

B = External setpoint and e Current Demand Control

Digit 26 - Output Controls

N = w/o control

A = Alarme relay output

C = Output Relay Icemaking

D = Alarm relay outputs and icemaking

Digit 27 - Reserved Digit

0 = Reserved

Digit 28 - Electrical Accessories

N = w/o Accessories

E = Nema-1 Flow Switch - 150 psi

Digit 29 - Electrical Board Accessories

N = w/o Accessories

Digit 30 - Service Valve

1 = Succion Service Valve

Digit 31 - Sound attenuator

0 = w/o sound attenuator

1 = w/ sound attenuator

Digit 32 - Panel Protection

N = w/o protection

A = Total Protection Panels

C = Coil Protection Panels

Digit 33 - Installation Accessories

N = w/o installation accessories

R = Neoprene Vibration Isolators

F = Flange kit for water connections

G = Neoprene Isolator and Flange Kit

Digit 34 - Reserved Digit

0 = Reserved

Digit 35 - Language - Literature/Stickers

P = Portuguese/Spanish

Digit 36 - Shipping Facility Accessories

0 = Reserved

Digit 37 - Security Devices

N = Standard

Digit 38 - Reserved Digit

0 = Reserved

Digit 39 - Reserved Digit

0 = Reserved

Digit 40 - Reserved Digit

0 = Reserved

Digit 41 - Reserved Digit

0 = Reserved

Digit 42 - Product Type

N = Standard

Z = Special



Features and Benefits

Tab. 01 - RTAC efficiency vs Ashrae 90.1

RTAC - Exceeding the Standard Efficiency						
60Hz	Efficiency under full load (EER*)			Efficiency under partial load (EER*)		
TR	ASHRAE 90.1	STD Efficiency	High efficiency	ASHRAE 90.1	STD Efficiency	High efficiency
140	9.6	9.7	10,3	10,4	13,5	14,0
155	9.6	9,8	10,4	10,4	13,6	14,1
170	9.6	9,9	10,4	10,4	13,9	14,4
185	9.6	9,7	10,3	10,4	13,7	14,2
200	9.6	9,6	10,1	10,4	13,3	13,9
225	9.6	9,6	10,2	10,4	13,4	14,0
250	9.6	9,6	10,1	10,4	13,6	13,8
275	9.6	9,8	10,5	10,4	13,3	13,7
300	9.6	9,6	10,2	10,4	13,3	13,6
350	9.6	9,6	-	10,4	13,1	-

COP = EER/3.414.

Efficiencies given for 60 Hz units

ASHRAE Standard 90.1 and RTAC World Class Energy Efficiency...

The importance of energy efficiency cannot be understated. Fortunately, ASHRAE has created a guideline emphasizing its importance.

Nonetheless, energy is often dismissed as an operational cost over which the owner has little control. That perception results in missed opportunities for energy efficiency, reduced utility bills, and higher profits. Lower utility bills directly affect profitability. Every dollar saved in energy goes directly to the bottom line. Trane's RTAC is one way to maximize your profits.

ASHRAE Standard 90.1 & Executive Order - New technology applied to the design, controls, and manufacturing have

created excellent efficiency levels in the RTAC that are helping to push industry minimums to new heights. All Trane air-cooled chillers meet the new efficiency levels mandated by ASHRAE Standard 90.1. This new standard requires higher efficiencies than past technologies can deliver.

Precise Capacity Control.

Trane's patented unloading system allows the compressor to modulate infinitely and exactly match building loads. At the same time chilled water temperatures will be maintained within +/- 1/2°F [0.28°C] of setpoint.

Reciprocating and screw chillers with stepped capacity control do well to maintain chilled water temperatures within 2°F [1.1°C] of setpoint. Stepped

control also results in overcooling your space because rarely does the capacity of the machine match the building load. The result can be 10% higher energy bills. Trane's RTAC optimizes the part load performance of your machine for energy efficiency, precise control for process applications, and your personal comfort regardless of the weather outside.

*ASHRAE: American Society of Heating, Refrigeration and Air-Conditioning.



Features and Benefits

Fig. 02 - Cutaway of a compressor

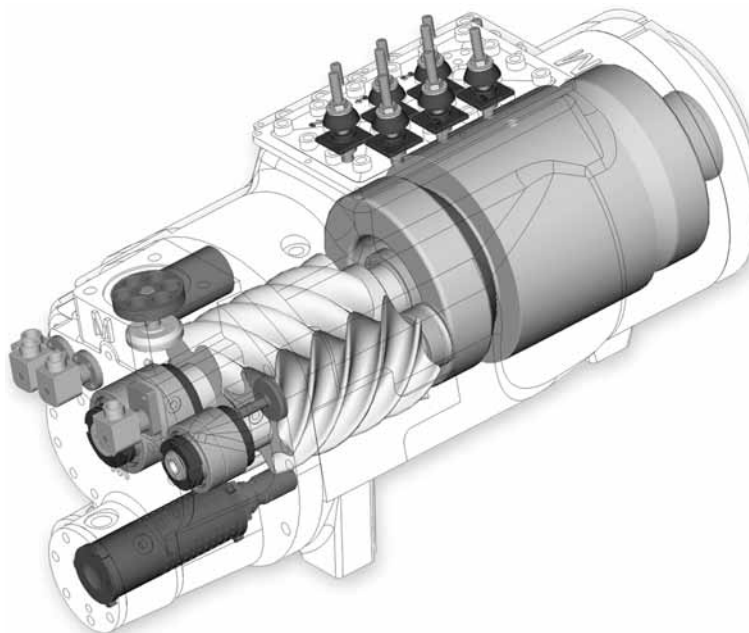

Excellent Reliability...

A buildings environment is expected to be comfortable. When it is, no one says a word. If it's not... that's a different story. The same is true with chillers. No one ever talks about chillers, yet alone compressors, until they fail, and tenants are uncomfortable and productivity is lost. Trane's helical rotary compressors have been designed and built to stay running when you need them.

Fewer moving parts. Trane's helical rotary compressors have only two major rotating parts: the male and female rotor. A reciprocating compressor can have more than 15 times that number of critical parts. Multiples of pistons, valves, crankshafts, and connecting rods in a reciprocating unit all represent different failure paths for the compressor. In fact, reciprocating compressors can easily have a failure rate four times of a helical rotor. Combine that with two to three reciprocating compressors for each helical rotary compressor on chillers of

equal tonnage, and statistics tell you it's a matter of time before you lose a reciprocating compressor.

Robust components. Helical rotary compressors are precisely machined using state of the art processes from solid metal bar stock. Tolerances are maintained within a micron or less than a tenth of the diameter of a human hair. The resulting compressor is a robust yet highly sophisticated assembly capable of ingesting liquid refrigerant without risk of damage. Contrast this to a reciprocating compressor, which can be destroyed by a single slug of liquid.

Condenser coils. Trane's condenser coils are manufactured with the same philosophy as the compressors; they're built to last. Even though manufacturing processes have allowed thinner and thinner materials in their assembly, with obvious material and manufacturing savings, Trane's coil material did not change with the RTAC generation of air cooled chillers. Substantial condenser

fins, that do not require additional coating in non-corrosive environments, contribute to the highest reliability standards for air-cooled chillers in the industry.



Features and Benefits

Superior Control

The Adaptive Control™ microprocessor system enhances the air-cooled Series R® chiller by providing the very latest chiller control technology. With the Adaptive Control microprocessor, unnecessary service calls and unhappy tenants are avoided. The unit is designed not to trip or unnecessarily shut down. Only when the Tracer™ chiller controllers have exhausted all possible corrective actions and the unit is still violating an operating limit will the chiller shut down. Controls on other equipment typically shut down the chiller, usually just when it is needed the most.

For example:

A typical five-year-old chiller with dirty coils might trip-out on high pressure cutout on a 100°F [38°C] day in August. A hot day is just when comfort cooling is needed the most. In contrast, the air-cooled Series R® chiller with an Adaptive Control microprocessor will stage fans on, modulate electronic expansion valve, and modulate slide valve position as it approaches a high pressure cutout, thereby keeping the chiller on-line when you need it the most.

Simple Installation

• **Compact Physical Size.** The Trane Model RTAC chiller averages a 20% reduction in physical footprint, while the greatest change is actually 40% smaller

when compared against the previous design. This improvement makes the RTAC the smallest air-cooled chiller in the industry and a prime candidate for installations that have space constraints. All physical sizes were changed without sacrificing the side clearances needed to supply fresh airflow without coil starvation.

• **Close Spacing Installation.** The air-cooled Series R™ Chiller has the tightest recommended side clearance in the industry, four feet for maximum performance. In situations where equipment must be installed with less clearance than recommended, which frequently occurs in retrofit applications, restricted airflow is common.

Conventional chillers may not work at all. However, the air-cooled Series R® chiller with Adaptive Control™ microprocessor will make as much chilled water as possible given the actual installed conditions, stay on line during unforeseen abnormal conditions, and optimize the unit performance. Consult your Trane sales engineer for more details.

• **Factory Testing Means Trouble-Free Start-Up.** All air-cooled Series R® chillers are given a complete functional test at the factory. This computer-based test program completely checks the sensors, wiring, electrical components, microprocessor

function, communication capability, expansion valve performance and fans. In addition, each compressor is run and tested to verify capacity and efficiency. Where applicable, each unit is factory preset to the customer's design conditions; an example would be leaving liquid temperature setpoint. The result of this test program is that the chiller arrives at the job site fully tested and ready for operation.

• **Factory Installed and Tested Controls/Options Speed Installation.** All Series R® chiller options, including main power supply disconnect, low ambient control, ambient temperature sensor, low ambient lockout, communication interface and ice making controls, are factory installed and tested. Some manufacturers send accessories in pieces to be field installed. With Trane, the customer saves on installation expense and has assurance that ALL chiller controls/options have been tested and will function as intended.

Fig. 03 - Minimum installation clearance requirements for no performance degradation

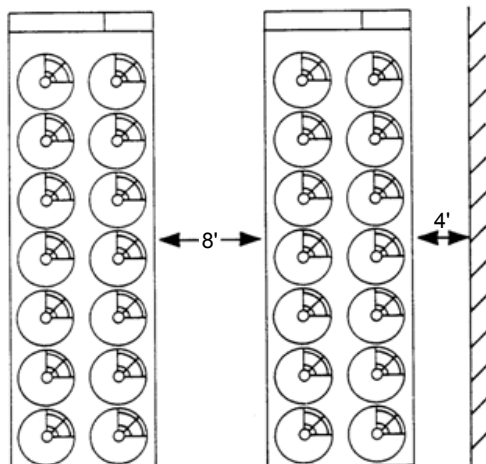



Features and Benefits

Options

High Efficiency/Performance Option

This option provides oversized heat exchangers for two purposes. One, it allows the unit to be more energy efficient. Two, the unit will have enhanced operation in high ambient conditions.

Low Temperature Brine

The hardware and software on the unit are factory set to handle low temperature brine applications (less than 40°F [4.4°C]).

Ice Making

The unit controls are factory set to handle ice making for thermal storage applications.

Tracer Summit Communication Interface

Permits bi-directional communication to the Trane Integrated Comfort™ system.

LonTalk (LCI-C) Communications Interface

Provides the LonMark chiller profile inputs/outputs for use with a generic building automation system.

Remote Input Options

Permits remote chilled liquid setpoint, remote current limit setpoint, or both by accepting a 4-20 mA or 2-10 Vdc analog signal.

Remote Output Options

Permits alarm relay outputs, ice making outputs, or both.

Access Protection

A coated wire mesh that covers the access area under the condenser coils.

Coil Protection

Louvered panels protect the condenser coils only.

Condenser Corrosion Protection

Copper fins and CompleteCoat are available on all size units for corrosion protection. Job site conditions should be matched with the appropriate condenser fin materials to inhibit coil corrosion and ensure extended equipment life. The CompleteCoat option provides fully assembled coils with a flexible dip and bake epoxy coating.

TEAO¹ Condenser Fan Motors (IPW55)

Totally enclosed air-over (TEAO) motors completely seal the motor windings to prevent exposure to ambient conditions.

Low Ambient Option

The low ambient option provides special control logic and variable frequency drives on the condenser fan circuits to permit low temperature start-up and operation down to 0°F [-18°C].

Non-Fused Power Disconnect Switch

The non-fused molded case disconnect switch (UL approved) is used to disconnect the chiller from main power and comes pre-wired from the factory with terminal block power connections. The external operator handle is lockable.

Circuit Breaker

A HACR rated molded case capacity circuit breaker (UL approved) is available. The circuit breaker can also be used to disconnect the chiller from main power with a through-the-door handle and comes pre-wired from the factory with terminal block power connections. The external operator handle is lockable.

Neoprene Isolators

Isolators provide isolation between chiller and structure to help eliminate

vibration transmission. Neoprene isolators are more effective and recommended over spring isolators.

Flange Kit

Provides a raised-face flange kit that converts the grooved pipe evaporator water connections to flange connectors.

NOTA:

1:TEAO – Totally Enclosed Air-Over.



Additional Information

Identification Tag

The RTAC identification tags are fixed on external control panel surface. The compressors tags are fixed on compressor.

An example of tag is shown below.

Fig. 04 - Identification Tag

 TRANE		<small>TRANE DO BRASIL IND.COM.PROD.COND.DE AR LTDA Av. dos Pinheiros,565 – Aracária – PR – Brasil</small>
MODELO / MODEL / MODELO		
RTAC350JBA0NN0FNATY2NDCN0NN10NN0PON0000N		
ITEM	RTAC350000002	
NÚMERO DE SÉRIE	B1109C0017	
SERIAL NUMBER		
NUMERO DE SERIE		
TAG	TAG1	
DATA DE FABRICAÇÃO	MANUFACTURING DATE FECHA DE FABRICACION	11/2009
ALIMENTAÇÃO ELÉTRICA	ELECTRICAL RATING SUMINISTRO ELÉCTRICO	380V / 60Hz
POTÊNCIA NOMINAL	POWER CONSUMPTION CONSUMO DE ENERGIA	410 kW
AMPACIDADE MÍNIMA	MINIMUM AMPACITY (MCA) AMPACIDAD MÍNIMA	594/275 A
CORRENTE DE PARTIDA	LOCKED ROTOR AMPS CORRIENTE DE ARRANQUE	923 A
MÁX. FUSÍVEL/DISJUNTOR	MAX. FUSE / BREAKER MAX. FUSIBLE / DISYUNTOR	800/450 A
TIPO DE REFRIGERANTE	REFRIGERANT TYPE TIPO DE REFRIGERANTE	R134a
TIPO DE ÓLEO	OIL TYPE TIPO DE ACEITE	TRANE OIL00048
CIRCUITO 1 / CIRCUIT 1		
COMPRESSOR	COMPRESSOR / COMPRESOR	02 X CHHP0N2
CARGA REFRIGERANTE	REFRIGERANT CHARGE / CARGA REFRIGERANTE	209 kg
CARGA DE ÓLEO	OIL CHARGE / CARGA DE ACEITE	19.0 L
MOTOR VENTILADOR	FAN MOTOR / MOTOR VENTILADOR	14 x 1.0HP
CIRCUITO 2 / CIRCUIT 2		
COMPRESSOR	COMPRESSOR / COMPRESOR	CHHP0N1
CARGA REFRIGERANTE	REFRIGERANT CHARGE / CARGA REFRIGERANTE	91 kg
CARGA DE ÓLEO	OIL CHARGE / CARGA DE ACEITE	8.0 L
MOTOR VENTILADOR	FAN MOTOR / MOTOR VENTILADOR	6 x 1.0HP
PRESSÃO DE TESTE (BAIXA/ALTA)	TEST PRESSURE (LOW/HIGH) PRESIÓN DE PRUEBA (BAJO/ALTO)	250/440 PSI
PESO	WEIGHT PESO	9738 Kg
<small>Indústria Brasileira Made in Brazil Hecho en Brasil</small>		



Application Considerations

Important

Certain application constraints should be considered when sizing, selecting and installing Trane air-cooled Series R® chillers. Unit and system reliability is often dependent upon proper and complete compliance with these considerations. When the application varies from the guidelines presented, it should be reviewed with your local Trane sales engineer.

Unit Sizing

Unit capacities are listed in the performance data section. Intentionally over-sizing a unit to assure adequate capacity is not recommended. Erratic system operation and excessive compressor cycling are often a direct result of an oversized chiller. In addition, an oversized unit is usually more expensive to purchase, install, and operate. If over-sizing is desired, consider using multiple units.

Water Treatment

Dirt, scale, products of corrosion and other foreign material will adversely affect heat transfer between the water and system components. Foreign matter in the chilled water system can also increase pressure drop and consequently, reduce water flow. Proper water treatment must be determined locally, depending on the type of system and local water characteristics. Neither

salt nor brackish water is recommended for use in Trane air-cooled Series R® chillers. Use of either will lead to a shortened life to an indeterminable degree. The Trane Company encourages the employment of a reputable water treatment specialist, familiar with local water conditions, to assist in this determination and in the establishment of a proper water treatment program.

Effect Of Altitude On Capacity

Air-cooled Series R® chiller capacities given in the performance data tables are for use at sea level. At elevations substantially above sea level, the decreased air density will reduce condenser capacity and, therefore, unit capacity and efficiency.

Ambient Limitations

Trane air-cooled Series R® chillers are designed for year-round operation over a range of ambient temperatures. The Model RTAC chiller will operate as standard in ambient temperatures of 25 to 115°F [-4 to 46°C]. With the low ambient option, these units will operate down to 0°F [-18°C]. If an ambient temperature as high as 125°F [51°C] is the basis for design, the high ambient option will permit the chiller to run without going into a limiting condition. For installations in areas with large ambient differences, the wide ambient

option will allow the chiller to perform uninhibited from 0 to 125°F [-18 to 51°C]. For operation outside these ranges, contact the local Trane sales office.

Water Flow Limits

The minimum and maximum water flow rates are given in Tables G-1 through G-4. Evaporator flow rates below the tabulated values will result in laminar flow causing freeze-up problems, scaling, stratification and poor control. Flow rates exceeding those listed may result in excessive tube erosion.

Flow Rates out of Range

Many process cooling jobs require flow rates that cannot be met with the minimum and maximum published values for the Model RTAC evaporator. A simple piping change can alleviate this problem. For example: A plastic injection molding process requires 80 gpm [5.1 l/s] of 50°F [10°C] water and returns that water at 60°F [15.6°C]. The selected chiller can operate at these temperatures, but has a minimum flow rate of 120 gpm [7.6 l/s]. The system layout in Figure A1 can satisfy the process.

Flow Control

Trane requires the chilled water flow control in conjunction with the Air-Cooled Series R® Chiller to be done by the chiller. This will allow the chiller to protect itself in potentially harmful conditions.

Fig. 05 - GPM out of range system layout

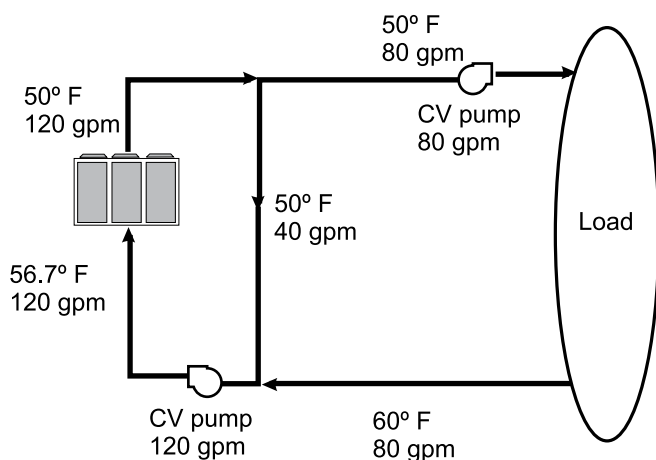



Application Considerations

Leaving Water Temperature Limits

Trane air-cooled Series R® chillers have three distinct leaving water categories: standard, low temperature, and ice making. The standard leaving solution temperature range is 40 to 60°F [4.4 to 15.6°C]. Low temperature machines produce leaving liquid temperatures less than 40°F [4.4°C]. Since liquid supply temperature setpoints less than 40°F [4.4°C] result in suction temperatures at or below the freezing point of water, a glycol solution is required for all low temperature machines. Ice making machines have a leaving liquid temperature range of 20 to 60°F [-6.7 to 15.6°C]. Ice making controls include dual setpoint controls and safeties for ice making and standard cooling capabilities. Consult your local Trane sales engineer for applications or selections involving low temperature or ice making machines. The maximum water temperature that can be circulated through an evaporator when the unit is not operating is 108°F [42°C].

Leaving Water Temperature out of Range

Many process cooling jobs require temperature ranges that cannot be met with the minimum and maximum published values for the Model RTAC evaporator. A simple piping change can alleviate this problem. For example: A laboratory load requires 120 gpm

[7.6 l/s] of water entering the process at 85°F [29.4°C] and returning at 95°F [35°C]. The accuracy required is better than the cooling tower can give. The selected chiller has adequate capacity, but a maximum leaving chilled water temperature of 60°F [15.6°C].

In Figure A2, both the chiller and process flow rates are equal. This is not necessary. For example, if the chiller had a higher flow rate, there would simply be more water bypassing and mixing with warm water.

Supply Water Temperature Drop

The performance data for the Trane air-cooled Series R® chiller is based on a chilled water temperature drop of 10°F [5.6°C]. Chilled water temperature drops from 6 to 18°F [3.3 to 10°C] may be used as long as minimum and maximum water temperatures and flow rates are not violated. Temperature drops outside this range are beyond the optimum range

Fig. 06 - Temperature out of range system layout

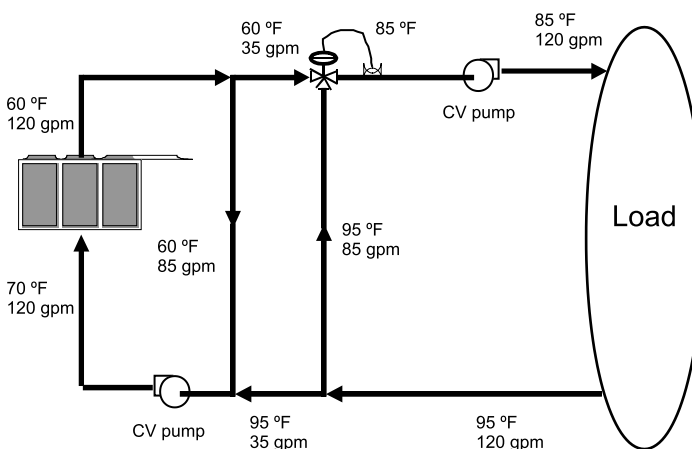

for control and may adversely affect the microcomputer's ability to maintain an acceptable supply water temperature range. Further, temperature drops of less than 6°F [3.3°C] may result in inadequate refrigerant superheat. Sufficient superheat is always a primary concern in any refrigerant system and is especially important in a package chiller where the evaporator is closely coupled to the compressor. When temperature drops are less than 6°F [3.3°C], an evaporator runaround loop may be required.

Variable Flow in the Evaporator

An attractive chilled water system option may be a variable primary flow (VPF) system. VPF systems present building owners with several cost-saving benefits that are directly related to the pumps. The most obvious cost savings result from eliminating the secondary distribution pump, which in turn avoids the expense incurred with the associated piping connections (material, labor), electrical service, and variable-frequency drive. Building owners often cite pump-related energy savings as the reason that prompted them to install a VPF system. With the help of a software analysis tool such as Trace 700 or Trace System Analyzer™ or DOE-2, you can determine whether the anticipated energy savings justify the use of variable primary flow in a particular application. It may also be easier to apply variable primary flow in an existing chilled-water plant. Unlike the "decoupled" system design, the bypass can be positioned at various points in the chilled-water loop

and an additional pump is unnecessary. The evaporator on the Model RTAC can withstand up to 50 percent water flow reduction as long as this flow is equal to or above the minimum flow rate requirements. The microprocessor and capacity control algorithms are designed to handle a maximum of 10% change in water flow rate per minute in order to maintain $\pm 0.5^\circ\text{F}$ [0.28°C] leaving evaporator temperature control. For applications in which system energy savings is most important and tight temperature control is classified as $\pm 2^\circ\text{F}$ [1.1°C], up to 30 percent changes in flow per minute are possible.



Application Considerations

Series Chiller Arrangements

Another energy-saving strategy is to design the system around chillers arranged in series. The actual savings possible with such strategies depends on the application dynamics and should be researched by consulting your Trane Systems Solutions Representative and applying an analysis tool from the Trace software family. It is possible to operate a pair of chillers more efficiently in a series chiller arrangement than in a parallel arrangement. It is also possible to achieve higher entering-to-leaving chiller differentials, which may, in turn, provide the opportunity for lower chilled water design temperature, lower design flow, and resulting installation and operational cost savings. The Trane screw compressor also has excellent

capabilities for “lift,” which affords an opportunity for savings on the evaporator water loop.

Series chiller arrangements can be controlled in several ways. Figure 07 shows a strategy where each chiller is trying to achieve the system design set point. If the cooling load is less than 50 percent of the systems capabilities, either chiller can fulfill the demand. As system loads increase, the Chiller 2 becomes preferentially loaded as it attempts to meet the leaving chilled water setpoint. Chiller 1 will finish cooling the leaving water from Chiller 2 down to the system design setpoint.

Staggering the chiller set points is another control technique that works well for preferentially loading Chiller 1. If the

cooling load is less than 50 percent of the system capacity, Chiller 1 would be able to satisfy the entire call for cooling. As system loads increase, Chiller 2 is started to meet any portion of the load that Chiller 1 can not meet.

Typical Water Piping

All building water piping must be flushed prior to making the final connections to the chiller. To reduce heat loss and prevent condensation, insulation should be installed. Expansion tanks are also usually required so that chilled water volume changes can be accommodated.

Fig. 07 - Typical series chiller arrangement

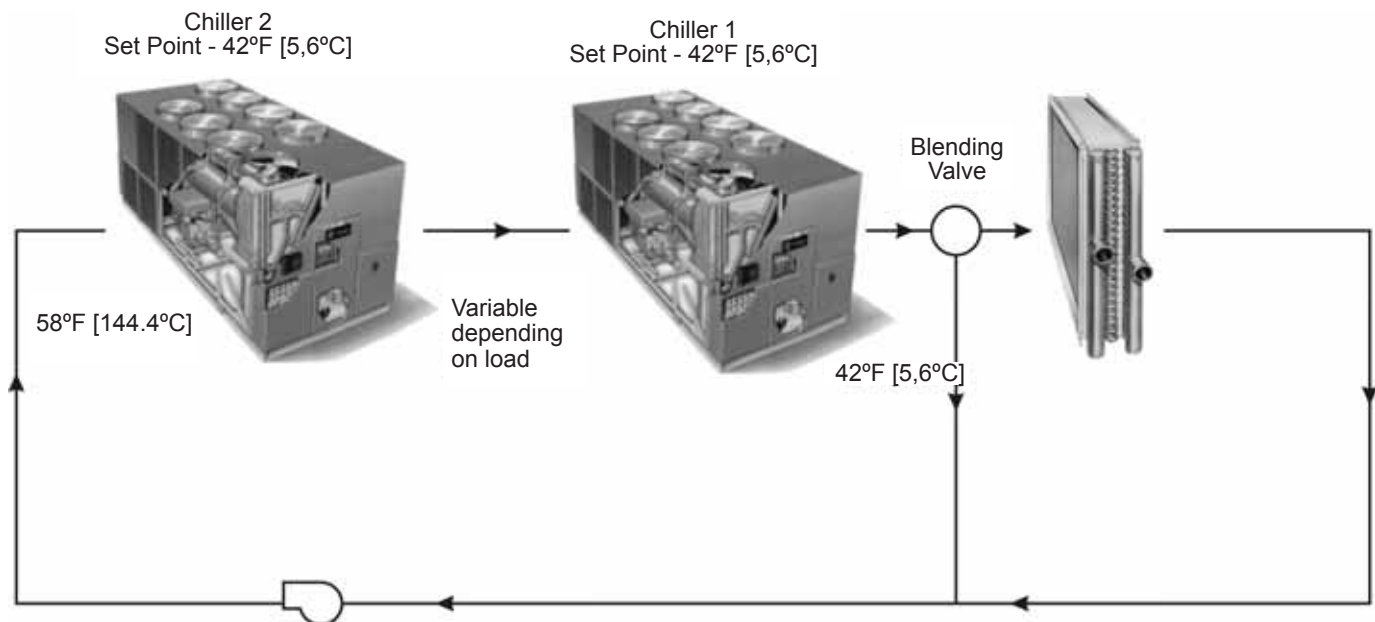

Application Considerations

Short Water Loops

The proper location of the temperature control sensor is in the supply (outlet) water connection or pipe. This location allows the building to act as a buffer and assures a slowly changing return water temperature. If there is not a sufficient volume of water in the system to provide an adequate buffer, temperature control can be lost, resulting in erratic system operation and excessive compressor cycling. A short water loop has the same effect as attempting to control from the building return water. Typically, a two-minute water loop is sufficient to prevent problems. Therefore, as a guideline, ensure the volume of water in the evaporator loop equals or exceeds two times the evaporator flow rate. For a rapidly changing load profile, the amount of volume should be increased. To prevent the effect of a short water loop, the following items should be given careful consideration: A storage tank or larger header pipe to increase the volume of water in the system and, therefore, reduce the rate of change of

the return water temperature.

Applications Types

- Comfort cooling.
- Industrial process cooling.
- Ice/thermal storage.
- Low temperature process cooling.

Typical Unit Installation

Outdoor HVAC equipment must be located to minimize noise and vibration transmission to the occupied spaces of the building structure it serves. If the equipment must be located in close proximity to a building, it could be placed next to an unoccupied space such as a storage room, mechanical room, etc. It is not recommended to locate the equipment near occupied, sound sensitive areas of the building or near windows. Locating the equipment away from structures will also prevent sound reflection, which can increase levels at property lines, or other sensitive points.

When physically isolating the unit from structures, it is a good idea to not use

rigid supports, and to eliminate any metal-to-metal or hard material contact, when possible. This includes replacing spring or metal weave isolation with elastomeric isolators. Figure 08 illustrates isolation recommendations for the RTAC.

Fig. 08 - Unit isolation recommendations

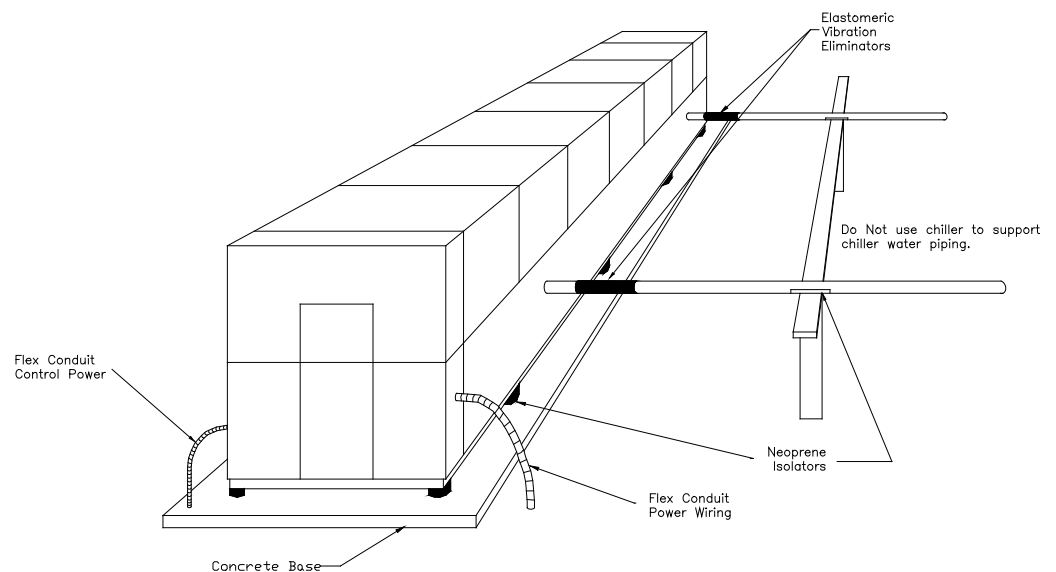



Application Considerations

System Options — Ice Storage

Trane air-cooled Series R® Chillers are well suited for ice production. An air-cooled machine typically switches to ice production at night. Two things happen under this assumption. First, the leaving brine temperature from the evaporator is lowered to around 22 to 24°F

[-5.5 to -4.4°C]. Second, the ambient temperature has typically dropped about 15 to 20°F [8.3 to 11°C] from the peak daytime ambient. This effectively places a lift on the compressors that is similar to daytime running conditions. The chiller can operate in lower ambient at night and successfully produce ice to supplement the next day's cooling demands.

The Model RTAC produces ice by supplying ice storage tanks with a constant supply of glycol solution. Air-cooled chillers selected for these lower leaving fluid temperatures are also selected for efficient production of chilled fluid at nominal comfort cooling conditions. The ability of Trane chillers to serve "double duty" in ice production and comfort cooling greatly reduces the capital cost of ice storage systems.

When cooling is required, ice chilled glycol is pumped from the ice storage tanks directly to the cooling coils. No expensive heat exchanger is required. The glycol loop is a sealed system, eliminating expensive annual chemical treatment costs. The air-cooled chiller is also available for comfort cooling

duty at nominal cooling conditions and efficiencies. The modular concept of glycol ice storage systems and the proven simplicity of Trane Tracer controllers allow the successful blend of reliability and energy saving performance in any ice storage application.

The ice storage system is operated in six different modes: each optimized for the utility cost of the hour.

1. Provide comfort cooling with chiller
2. Provide comfort cooling with ice
3. Provide comfort cooling with ice and chiller
4. Freeze ice storage
5. Freeze ice storage when comfort cooling is required
6. Off

Tracer optimization software controls operation of the required equipment and accessories to easily transition from one mode of operation to another. For example:

Even with ice storage systems there are numerous hours when ice is neither produced or consumed, but saved. In this mode the chiller is the sole source of cooling. For example, to cool the building after all ice is produced but before high electrical demand charges take effect, Tracer sets the air-cooled chiller leaving fluid setpoint to its most efficient setting and starts the chiller, chiller pump, and load pump.

When electrical demand is high, the ice pump is started and the chiller is either

demand limited or shut down completely. Tracer controls have the intelligence to optimally balance the contribution of ice and chiller in meeting the cooling load.

The capacity of the chiller plant is extended by operating the chiller and ice in tandem. Tracer rations the ice, augmenting chiller capacity while reducing cooling costs. When ice is produced, Tracer will lower the air-cooled chiller leaving fluid setpoint and start the chiller, ice and chiller pumps, and other accessories. Any incidental loads that persist while producing ice can be addressed by starting the load pump and drawing spent cooling fluid from the ice storage tanks.

For specific information on ice storage applications, contact your local Trane sales office.

Fig. 09 - Ice storage demand cost savings

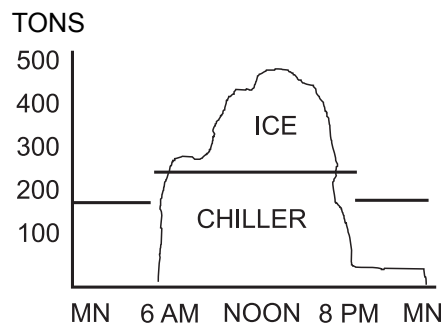



General Data

Tab. 01 - General data — 140-350 ton 60 Hz units - standard efficiency

Size		140	155	170	185	200	225	250	275	300	350
Type		STD	STD	STD	STD	STD	STD	STD	STD	STD	STD
Compressor											
Quantity		2	2	2	2	2	2	2	3	3	3
Nominal Size	Tons	70/70	85/70	85/85	100/85	100/100	120/100	120/120	85-85/100	100-100/100	120-120/100
Evaporator											
	(gallons)	29	32	33	35	39	38	42	60	65	70
Water storage	(liters)	111	121	127	134	146	145	158	229	245	264
2 pass arrangement											
	(gpm)	193	214	202	217	241	217	241	309	339	375
Minimum flow	(l/s)	12	14	13	14	15	14	15	20	21	24
	(gpm)	709	785	741	796	883	796	883	1134	1243	1374
Maximum flow	(l/s)	45	50	47	50	56	50	56	72	78	87
3 Pass arrangement											
	(gpm)	129	143	135	145	161	145	161	206	226	250
Minimum flow	(l/s)	8	9	9	9	10	9	10	13	14	16
	(gpm)	473	523	494	531	589	531	589	756	829	916
Maximum flow	(l/s)	30	33	31	33	37	33	37	48	52	58
Condenser											
Qty of coils		4	4	4	4	4	4	4	8	8	8
	(inches)	156/156	180/156	180/180	216/180	216/216	252/216	252/252	180/108	216/108	252/108
Coil length	(mm)	3962/3962	4572/3962	4572/4572	5486/4572	5486/5486	6401/5486	6401/6401	4572/2743	5486/2743	6401/4572
	(inches)	42	42	42	42	42	42	42	42	42	42
Coil height	(mm)	1067	1067	1067	1067	1067	1067	1067	1067	1067	1067
Fins/Ft		192	192	192	192	192	192	192	192	192	192
Number of rows		3	3	3	3	3	3	3	3	3	3
Condenser fans											
Quantity		4/4	5/4	5/5	6/5	6/6	7/6	7/7	10/6	12/6	14/6
	(inches)	30	30	30	30	30	30	30	30	30	30
Diameter	(mm)	762	762	762	762	762	762	762	762	762	762
	(cfm)	77000	84542	92087	101296	110506	119725	128946	147340	165766	184151
Total airflow	(m ³ /h)	130811	143623	156441	172086	187732	203394	219059	250307	281610	312843
Nominal fan speed	(rpm)	1140	1140	1140	1140	1140	1140	1140	1140	1140	1140
	(rps)	19	19	19	19	19	19	19	19	19	19
	(ft/min)	8954	8954	8954	8954	8954	8954	8954	8954	8954	8954
Tip Speed	(m/s)	45	45	45	45	45	45	45	45	45	45
Motor Power	HP	1,0	1,0	1,0	1,0	1,0	1,0	1,0	1,0	1,0	1,0
Minimum starting/ operating ambient (2)	(kW)	0,75	0,75	0,75	0,75	0,75	0,75	0,75	0,75	0,75	0,75
Std Unit											
Low ambient	(°F)	25	25	25	25	25	25	25	25	25	25
	(°C)	-3,9	-3,9	-3,9	-3,9	-3,9	-3,9	-3,9	-3,9	-3,9	-3,9
General unit	(°F)	0	0	0	0	0,0	0	0	0	0	0
	(°C)	-17,8	-17,8	-17,8	-17,8	-17,8	-17,8	-17,8	-17,8	-17,8	-17,8
Refrigerant											
		HFC-134a	HFC-134a	HFC-134a	HFC-134a	HFC-134a	HFC-134a	HFC-134a	HFC-134a	HFC-134a	HFC-134a
N° of independent refrigerant circuits		2	2	2	2	2	2	2	2	2	2
% Minimum Load		15	15	15	15	15	15	15	15	15	15
	(pounds)	165/165	175/165	175/175	215/210	215/215	225/215	225/225	365/200	415/200	460/200
Refrigerant charge (1)	(kg)	75/75	79/75	79/79	98/95	98/98	102/98	102/102	166/91	188/91	209/91
	(gallons)	1.5/1.5	1.5/1.5	1.5/1.5	2.1/1.5	2.1/2.1	2.1/2.1	2.1/2.1	4.6/2.1	5.0/2.1	5.0/2.1
Oil charge (1)	(liters)	6/6	6/6	6/6	6/8	8/8	8/8	8/8	17/8	19/8	19/8

Notes:

1. Data containing information on two circuits shown as follows: CKT 1/CKT 2
2. Minimum start-up/operating ambient based on a 5 mph wind across the condenser



General Data

Tab. 02 - General data — 140-400 ton 60 Hz units - high efficiency

Size		140	155	170	185	200	225	250	275	300
Type		HIGH	HIGH	HIGH	HIGH	HIGH	HIGH	HIGH	HIGH	HIGH
Compressor										
Quantity		2	2	2	2	2	2	2	3	3
Nominal Size	Tons	70/70	85/70	85/85	100/85	100/100	120/100	120/120	85-85/100	100-100/100
Evaporator										
	(gallons)	33	35	39	38	42	42	42	70	70
Water Storage	(liters)	127	134	146	145	158	158	158	264	264
2 Pass Arrangement										
	(gpm)	202	217	241	217	241	241	241	375	375
Min. Flow	(l/seg.)	13	14	15	14	15	15	15	24	24
	(gpm)	741	796	883	796	883	883	883	1374	1374
Max. Flow	(l/seg.)	47	50	56	50	56	56	56	87	87
3 Pass Arrangement										
	(gpm)	135	145	161	145	161	161	161	250	250
Min. Flow	(l/seg.)	9	9	10	9	10	10	10	16	16
	(gpm)	494	531	589	531	589	589	589	916	916
Max. Flow	(l/seg.)	31	33	37	33	37	37	37	58	58
Condenser										
Quantity of Coils		4	4	4	4	4	8	8	8	8
Coil Length	(inches)	180/180	216/180	216/216	252/216	252/252	144/144	144/144	216/144	252/144
	(mm)	4572/4572	5486/4572	5486/5486	6401/5486	6401/6401	3658/3658	4572/2743	5486/3658	6401/3658
Coil Height	(inches)	42	42	42	42	42	42	42	42	42
	(mm)	1067	1067	1067	1067	1067	1067	1067	1067	1067
Fins/ ft		192	192	192	192	192	192	192	192	192
Number of Rows		3	3	3	3	3	3	3	3	3
Condenser Fins										
Quantity		5/5	6/5	6/6	7/6	7/7	8/6	8/8	12/6	14/6
Diameter	(inches)	30	30	30	30	30	30	30	30	30
	(mm)	762	762	762	762	762	762	762	762	762
Total Airflow	(cfm)	91993	101190	110387	119598	128812	136958	147242	173733	192098
	(m ³ /h)	156281	171906	187530	203178	218831	232670	250141	295145	326344
Nominal Fan Speed	(rpm)	1140	1140	1140	1140	1140	1140	1140	1140	1140
	(rps)	19	19	19	19	19	19	19	19	19
Tip Speed	(ft/min)	8954	8954	8954	8954	8954	8954	8954	8954	8954
	(m/s)	45	45	45	45	45	45	45	45	45
Motor Nominal (Ea)	HP	1,0	1,0	1,0	1,0	1,0	1,0	1,0	1,0	1,0
Min Starting/ Oper Ambient	(kW)	0,75	0,75	0,75	0,75	0,75	0,75	0,75	0,75	0,75
Std Unit										
Low Ambient	(°F)	25	25	25	25	25	25	25	25	25
	(°C)	-3,9	-3,9	-3,9	-3,9	-3,9	-3,9	-3,9	-3,9	-3,9
General Ambient	(°F)	0	0	0	0	0	0	0	0	0
	(°C)	-17,8	-17,8	-17,8	-17,8	-17,8	-17,8	-17,8	-17,8	-17,8
Refrigerant										
		HFC-134a	HFC-134a	HFC-134a	HFC-134a	HFC-134a	HFC-134a	HFC-134a	HFC-134a	HFC-134a
N° of independent refrigerant circuits		2	2	2	2	2	2	2	2	2
% Min. Load		15	15	15	15	15	15	15	15	15
	(lb)	175/175	215/205	215/215	225/215	225/225	235/235	235/235	415/200	460/200
Refrigerant Charge	(kg)	79/79	98/93	98/98	102/98	102/102	107/107	107/107	188/91	209/91
	(gallons)	1.5/1.5	1.5/1.5	1.5/1.5	2.1/1.5	2.1/2.1	2.1/2.1	2.1/2.1	4.6/2.2	5.0/2.2
Oil Charge	(liters)	6/6	6/6	6/6	6/8	8/8	8/8	8/8	17/8	19/8

Notes:

1. Data containing information on two circuits shown as follows: CKT 1/CKT 2
2. Minimum start-up/operating ambient based on a 5 mph wind across the condenser



General Data

Tab. 03 - General data — 140-400 ton 50 Hz units - standard efficiency

Size		140	155	170	185	200	250	275	300	350
Type		STD	STD	STD	STD	STD	STD	STD	STD	STD
Compressor										
Quantity		2	2	2	2	2	3	3	3	4
Nominal Size	Tons	70/70	85/70	85/85	100/85	100/100	70-70/100	85-85/100	100-100/100	85-85/85-85
Evaporator										
Water Storage	(gallons)	29	32	33	35	39	54	60	66	71
	(liters)	111	121	127	134	146	205	227	249	265
2 Pass arrangement										
	(gpm)	193	214	202	217	241	265	309	339	351
Min. Flow	(l/seg.)	12	14	13	14	16	15	17	20	29
	(gpm)	709	785	741	796	883	883	1134	1243	1374
Max. Flow	(l/seg.)	45	50	47	50	56	56	72	78	87
3 Pass arrangement										
	(gpm)	129	143	135	145	161	176	206	226	234
Min. Flow	(l/seg.)	8	9	9	9	10	11	13	14	15
	(gpm)	473	523	494	531	589	647	756	829	858
Max. Flow	(l/seg.)	30	33	31	33	37	41	48	52	54
Condenser										
Quantity of Coils		4	4	4	4	4	8	8	8	8
Coil Length	(inches)	156/156	180/156	180/180	216/180	216/216	156/108	180/108	216/108	180/180
	(mm)	3962/3962	4572/3962	4572/4572	5486/4572	5486/5486	3962/4572	4572/2743	5486/2743	4572/4572
Coil Height	(inches)	42	42	42	42	42	42	42	42	42
	(mm)	1067	1067	1067	1067	1067	1067	1067	1067	1067
Fins/ Ft		192	192	192	192	192	192	192	192	192
Number of Rows		3	3	3	3	3	3	3	3	3
Condenser Fans										
Quantity		4/4	5/4	5/5	6/5	6/6	8/6	10/6	12/6	10/10
Diameter	(inches)	30	30	30	30	30	30	30	30	30
	(mm)	762	762	762	762	762	762	762	762	762
Total AirFlow	(cfm)	63346	69507	75671	83236	90803	108698	121056	136210	151332
	(m ³ /h)	107615	118081	128553	141405	141405	184661	205655	231399	257089
Nominal Fan Speed	(rpm)	950	950	950	950	950	950	950	950	950
	(rps)	15,8	15,8	15,8	15,8	15,8	15,8	15,8	15,8	15,8
Tip Speed	(ft/min)	7461	7461	7461	7461	7461	7461	7461	7461	7461
	(m/s)	38	38	38	38	38	38	38	38	38
Motor nominal (Ea)	HP	1,5	1,5	1,5	1,5	1,5	1,5	1,5	1,5	1,5
Min. Starting/ Oper Ambient	(kW)	1,1	1,1	1,1	1,1	1,1	1,1	1,1	1,1	1,1
Std. Unit										
Low ambient	(°F)	25	25	25	25	25	25	25	25	25
	(°C)	-3,9	-3,9	-3,9	-3,9	-3,9	-3,9	-3,9	-3,9	-3,9
General Unit	(°F)	0	0	0	0	0	0	0	0	0
	(°C)	-17,8	-17,8	-17,8	-17,8	-17,8	-17,8	-17,8	-17,8	-17,8
Refrigerant										
N° of independent refrigerant circuits		HFC-134a	HFC-134a	HFC-134a	HFC-134a	HFC-134a	HFC-134a	HFC-134a	HFC-134a	HFC-134a
% min. load	(lb)	165/165	175/165	175/175	215/210	215/215	335/200	365/200	415/200	365/365
Refrigerant charge	(kg)	75/75	79/75	79/79	98/95	98/98	152/91	166/91	188/91	166/166
	(gallons)	1.5/1.5	1.5/1.5	1.5/1.5	2.1/1.5	2.1/2.1	4.6/2.1	4.6/2.1	5.0/2.1	4.6/4.6
Oil charge	(liters)	6/6	6/6	6/6	6/8	8/8	17/8	17/8	19/8	17/17

Notes:

1. Data containing information on two circuits shown as follows: CKT 1/CKT 2
2. Minimum start-up/operating ambient based on a 5 mph wind across the condenser



General Data

Tab. 04 - General data — 140-400 ton 50 Hz units - high efficiency

Size		140	155	170	185	200	250	275	300
Type		HIGH	HIGH	HIGH	HIGH	HIGH	HIGH	HIGH	HIGH
Compressor									
Quantity		2	2	2	2	2	3	3	3
Nominal Size	Tons	70/70	85/70	85/85	100/85	100/100	70-70/100	85-85/100	100-100/100
Evaporator									
Water Storage	(gallons)	33	35	39	38	42	66	71	71
	(liters)	127	134	146	145	158	249	267	267
2 Pass arrangement									
	(gpm)	202	217	241	217	241	241	241	375
Min. Flow	(l/seg.)	13	14	15	14	15	15	15	24
Max. Flow	(gpm)	741	796	883	796	883	883	883	1374
	(l/seg.)	47	50	56	50	56	56	56	87
3 Pass arrangement									
	(gpm)	135	145	161	145	161	226	250	250
Min. Flow	(l/seg.)	9	9	10	9	10	14	16	16
	(gpm)	494	531	589	531	589	829	916	916
Max. Flow	(l/seg.)	31	33	37	33	37	52	58	58
Condenser									
Qty of Coils		4	4	4	4	4	8	8	8
Coil Legth	(inches)	180/180	216/180	216/216	252/216	252/252	180/108	216/144	252/144
	(mm)	4572/4572	5486/4572	5486/5486	6401/5486	6401/6401	4572/2743	5486/3658	6401/3658
Coil Height	(inches)	42	42	42	42	42	42	42	42
	(mm)	1067	1067	1067	1067	1067	1067	1067	1067
Fins/ Ft		192	192	192	192	192	192	192	192
Number of Rows		3	3	3	3	3	3	3	3
Condenser Fans									
Quantity		5/5	6/5	6/6	7/6	7/7	10/6	12/6	14/6
Diameter	(inches)	30	30	30	30	30	30	30	30
	(mm)	762	762	762	762	762	762	762	762
Total Airflow	(cfm)	75575	83130	90687	98256	105826	120971	142969	158112
	(m ³ /h)	128390	141225	154063	166921	179781	205510	242881	268607
Nominal Fan Speed	(rpm)	950	950	950	950	950	950	950	950
	(rps)	15,8	15,8	15,8	15,8	15,8	15,8	15,8	15,8
	(ft/min)	7461	7461	7461	7461	7461	7461	7461	7461
Tip Speed	(m/s)	38	38	38	38	38	38	38	38
Motor Nominal (Ea)	HP	1.5	1.5	1.5	1.5	1.5	1.5	1.5	1.5
Min Starting/ Oper Ambient	(kW)	1.1	1.1	1.1	1.1	1.1	1.1	1.1	1.1
Std. Unit									
Low Ambient	(°F)	25	25	25	25	25	25	25	25
	(°C)	-3,9	-3,9	-3,9	-3,9	-3,9	-3,9	-3,9	-3,9
General Unit	(°F)	0	0	0	0	0	0	0	0
	(°C)	-17,8	-17,8	-17,8	-17,8	-17,8	-17,8	-17,8	-17,8
Refrigerant									
		HFC-134a	HFC-134a	HFC-134a	HFC-134a	HFC-134a	HFC-134a	HFC-134a	HFC-134a
N° of independent refrigerant circuits		2	2	2	2	2	2	2	2
% Min. Load		15	15	15	15	15	15	15	15
Refrigerant Charge	(lb)	175/175	215/205	215/215	225/215	225/225	335/195	385/15	430/215
	(kg)	79/79	98/93	98/98	102/98	102/102	152/88	175/97	195/97
Oil Charge	(galones)	1.5/1.5	1.5/1.5	1.5/1.5	2.1/1.5	2.1/2.1	4.6/2.1	4.6/2.1	5.0/2.1
	(l)	6/6	6/6	6/6	8/6	8/8	17/8	17/8	19/8

Notes:

1. Data containing information on two circuits shown as follows: CKT 1/CKT 2
2. Minimum start-up/operating ambient based on a 5 mph wind across the condenser



Selection Procedure

Trane air-cooled Series R® chiller performance is rated in accordance with the ARI Standard 550/590-1998 Certification Program. Chiller selection assistance and performance information can be obtained by using the Series R® chiller selection program, available through local Trane sales offices.

The chiller capacity tables cover the most frequently encountered leaving liquid temperatures. The tables reflect a 10°F [5.6°C] temperature drop through the evaporator. For other temperature drops, apply the appropriate Performance Data Adjustment Factors from Table A-1. For chilled brine selections, contact your local Trane sales engineer. To select a Trane air-cooled Series R® chiller, the following information is required:

- 1 - Design load in tons of refrigeration
- 2 - Design chilled water temperature drop
- 3 - Design leaving chilled water temperature
- 4 - Design ambient temperature

Evaporator flow rates can be determined by using the following formulas:

$$\text{GPM} = (\text{Tons} \times 24) / \text{Temperature Drop (Degrees F)}$$

OR

$$\text{L/S} = (\text{kW (Capacity)} \times .239) / \text{Temperature Drop (Degrees C)}$$

NOTE: Flow rates must fall within the limits specified in Tables G-1 through

G-4 (for GPM or for L/s).

Selection Example

Given:

Required System Load = 140 Tons
 Leaving Chilled Water Temperature (LCWT) = 44°F
 Chilled Water Temperature Drop = 10°F
 Design Ambient Temperature = 95°F

Evaporator Fouling Factor = 0.0001

1 - To calculate the required chilled water flow rate we use the formula given below:

$$\text{GPM} = (140 \text{ Tons} \times 24) / 10^\circ\text{F} = 336 \text{ GPM}$$

2 - From Table P-1 (RTAC performance data), an RTAC 140 standard at the given conditions will produce 138.2 tons with compressor power input of 158.6 kW and a unit EER of 9.7.

3 - To determine the evaporator pressure drop use the flow rate (GPM) and pressure drop chart on page 37. Entering the curve at 336 gpm, the pressure drop for a nominal 140 standard evaporator is approximately 16 feet.

Minimum Leaving Chilled Water Temperature Setpoint

The minimum leaving chilled water temperature setpoint for water is 40°F. For those applications requiring lower setpoints, a glycol solution must be used. Contact the local Trane sales engineer for additional information.

Tab. 05 - Performance data adjustment factors

Fouling Factor	Chiller Water Temp.	Elevation											
		Seal Level			2000 ft			4000 ft			6000 ft		
		CAP	GPM	kW	CAP	GPM	kW	CAP	GPM	kW	CAP	GPM	kW
0.0001	8	0.997	1,246	0.999	0.987	1,233	1,012	0.975	1,217	1,027	0.960	1,200	1,045
	10	1.000	1,000	1,000	0.989	0,989	1,013	0.977	0,977	1,028	0.963	0,963	1,047
	12	1.003	0,835	1,001	0.992	0,826	1,014	0.979	0,816	1,030	0.965	0,804	1,048
	14	1.004	0,717	1,002	0.993	0,710	1,016	0.981	0,701	1,031	0.966	0,690	1,049
	16	1.006	0,629	1,003	0.995	0,622	1,016	0.982	0,614	1,032	0.968	0,605	1,050
0.00025	8	0.982	1,227	0.991	0.972	1,215	1,003	0.961	1,200	1,018	0.947	1,183	1,036
	10	0.986	0,985	0.992	0.975	0,975	1,005	0.963	0,963	1,020	0.950	0,950	1,038
	12	0.988	0,823	0.994	0.978	0,815	1,006	0.966	0,805	1,022	0.952	0,793	1,040
	14	0.991	0,708	0.995	0.980	0,700	1,008	0.968	0,692	1,023	0.954	0,682	1,041
	16	0.992	0,621	0.996	0.982	0,614	1,009	0.970	0,606	1,024	0.956	0,598	1,042



Performance Data

Full Load Performance

Tab. 06a - 60 Hz standard efficiency machines in English units

Evaporator Leaving Water Temperature (F)	Unit Size Model RTAC	Condenser Entering Air Temperature (F)											
		85			95			105			115		
		Input Tons	Input kW	EER	Input Tons	Input kW	EER	Input Tons	Input kW	EER	Input Tons	Input kW	EER
40	140 STD	138.0	139.9	10.9	128.4	152.4	9.4	118.5	166.4	8.0	108.4	182.1	6.7
	155 STD	151.4	152.3	10.9	141.1	165.9	9.4	130.4	181.2	8.0	119.5	198.3	6.8
	170 STD	165.6	165.0	11.0	154.5	179.8	9.5	143.1	196.5	8.1	131.5	215.0	6.9
	185 STD	180.5	183.4	10.8	168.6	199.4	9.4	156.2	217.5	8.0	143.5	237.8	6.8
	200 STD	196.6	202.7	10.7	183.6	219.8	9.3	170.1	239.3	7.9	156.2	261.2	6.7
	225 STD	215.5	221.8	10.7	201.6	240.7	9.3	187.1	262.1	8.0	172.0	286.2	6.8
	250 STD	236.1	242.2	10.8	220.9	262.7	9.4	205.1	285.9	8.0	188.8	312.0	6.8
	275 STD	267.1	268.2	11.0	249.4	291.5	9.5	231.2	317.8	8.1	212.5	347.2	6.9
	300 STD	298.4	307.1	10.7	278.8	332.7	9.3	258.5	361.8	8.0	237.5	394.5	6.8
	350 STD	338.2	348.1	10.7	316.4	376.8	9.3	293.7	409.5	8.0	270.2	446.3	6.8
42	140 STD	143.2	142.9	11.1	133.3	155.5	9.5	123.1	169.6	8.1	112.6	185.4	6.9
	155 STD	157.1	155.5	11.1	146.4	169.2	9.6	135.4	184.7	8.2	124.2	201.8	6.9
	170 STD	171.7	168.5	11.2	160.3	183.4	9.7	148.6	200.2	8.3	136.6	218.8	7.0
	185 STD	187.2	187.4	11.0	174.8	203.5	9.5	162.1	221.7	8.2	149.0	242.1	6.9
	200 STD	203.8	207.2	10.8	190.3	224.4	9.4	176.4	244.1	8.1	162.1	266.1	6.9
	225 STD	223.4	226.9	10.9	208.9	245.9	9.5	193.9	267.5	8.1	178.4	291.7	6.9
	250 STD	244.8	247.9	10.9	229.0	268.5	9.5	212.7	292.0	8.2	195.7	318.2	6.9
	275 STD	276.9	274.0	11.1	258.6	297.4	9.7	239.9	323.9	8.3	220.6	353.4	7.0
	300 STD	309.2	314.0	10.9	288.9	339.7	9.5	268.0	369.0	8.1	246.3	401.9	6.9
	350 STD	350.6	356.2	10.9	327.9	385.2	9.5	304.4	418.1	8.2	280.1	455.1	6.9
44	140 STD	148.4	146.0	11.3	138.2	158.6	9.7	127.7	172.9	8.3	116.9	188.7	7.0
	155 STD	162.9	158.8	11.3	151.9	172.6	9.8	140.5	188.2	8.4	128.9	205.4	7.1
	170 STD	177.9	172.0	11.4	166.2	187.0	9.9	154.1	203.9	8.5	141.8	222.6	7.2
	185 STD	193.9	191.4	11.2	181.2	207.6	9.7	168.0	226.0	8.3	154.5	246.4	7.1
	200 STD	211.0	211.8	11.0	197.2	229.2	9.6	182.8	248.9	8.2	168.0	271.1	7.0
	225 STD	231.3	232.1	11.0	216.4	251.2	9.6	200.9	272.9	8.3	184.8	297.3	7.0
	250 STD	253.5	253.8	11.1	237.2	274.6	9.6	220.3	298.2	8.3	202.7	324.5	7.1
	275 STD	286.8	279.9	11.3	268.0	303.4	9.8	248.7	330.1	8.4	228.8	359.8	7.2
	300 STD	320.2	321.0	11.0	299.2	346.9	9.6	277.6	376.3	8.3	255.3	409.4	7.0
	350 STD	363.1	364.6	11.0	339.6	393.8	9.6	315.3	426.9	8.3	290.1	464.0	7.1

Notes:

1. Ratings based on sea level altitude and evaporator fouling factor of 0.00010.
2. Consult Trane representative for performance at temperatures outside of the ranges shown.
3. kW input is for compressors only.
4. EER = Energy Efficiency Ratio (Btu/watt-hour). Power inputs include compressors, condenser fans and control power.
5. Ratings are based on an evaporator temperature drop of 10°F and the standard evaporator pass arrangement.
6. Ambient temperatures 115°F and greater reflect the high ambient condenser option.
7. Interpolation between points is permissible. Extrapolation is not permitted.
8. Rated in accordance with ARI Standard 550/590.



Performance Data

Full Load Performance

Tab. 06b -60 Hz standard efficiency machines in English units (Continued)

Evaporator Leaving Water Temperature (F)	Unit Size Model RTAC	Condenser Entering Air Temperature (F)											
		85			95			105			115		
		Tons	Input kW	EER	Tons	Input kW	EER	Tons	Input kW	EER	Tons	Input kW	EER
46	140 STD	153.8	149.1	11.4	143.3	161.8	9.9	132.4	176.2	8.4	121.2	192.1	7.1
	155 STD	168.7	162.2	11.5	157.4	176.1	10.0	145.7	191.7	8.5	133.7	209.1	7.2
	170 STD	184.2	175.6	11.6	172.2	190.7	10.0	159.8	207.7	8.6	147.1	226.5	7.3
	185 STD	200.7	195.6	11.3	187.6	211.9	9.9	174.1	230.3	8.5	160.2	250.9	7.2
	200 STD	218.4	216.5	11.2	204.1	234.0	9.7	189.3	253.9	8.4	174.0	276.2	7.1
	225 STD	239.3	237.4	11.2	223.9	256.7	9.7	207.9	278.5	8.4	191.3	303.0	7.1
	250 STD	262.4	259.8	11.2	245.6	280.8	9.8	228.0	304.5	8.4	209.8	331.0	7.2
	275 STD	296.9	286.0	11.5	277.6	309.6	10.0	257.6	336.4	8.6	237.2	366.2	7.3
	300 STD	331.3	328.2	11.2	309.7	354.2	9.8	287.4	383.8	8.4	264.3	417.1	7.2
	350 STD	375.7	373.2	11.2	351.5	402.6	9.8	326.3	435.8	8.4	300.3	473.1	7.2
48	140 STD	159.2	152.4	11.6	148.4	165.2	10.0	137.1	179.6	8.6	125.6	195.6	7.3
	155 STD	174.7	165.7	11.7	163.0	179.7	10.1	151.0	195.4	8.7	138.6	212.8	7.4
	170 STD	190.6	179.3	11.8	178.2	194.5	10.2	165.5	211.6	8.8	152.4	230.5	7.5
	185 STD	207.6	199.8	11.5	194.1	216.2	10.0	180.2	234.8	8.6	165.9	255.4	7.3
	200 STD	225.8	221.3	11.3	211.1	238.9	9.9	195.9	258.9	8.5	180.1	281.3	7.2
	225 STD	247.5	242.8	11.3	231.6	262.2	9.9	215.1	284.2	8.5	197.9	308.8	7.3
	250 STD	271.4	266.0	11.4	254.0	287.1	9.9	235.8	311.0	8.5	216.9	337.6	7.3
	275 STD	307.2	292.2	11.6	287.2	316.0	10.1	266.7	342.8	8.7	245.6	372.8	7.4
	300 STD	342.6	335.6	11.3	320.3	361.7	9.9	297.3	391.5	8.5	273.5	424.9	7.3
	350 STD	388.6	382.1	11.3	363.5	411.6	9.9	337.5	445.0	8.5	304.5	469.5	7.3
50	140 STD	164.7	155.7	11.8	153.5	168.5	10.2	141.9	183.0	8.7	130.1	199.1	7.4
	155 STD	180.7	169.3	11.9	168.7	183.3	10.3	156.3	199.1	8.8	143.6	216.5	7.5
	170 STD	197.1	183.1	11.9	184.4	198.4	10.4	171.2	215.5	8.9	157.8	234.5	7.6
	185 STD	214.6	204.1	11.7	200.7	220.6	10.2	186.4	239.3	8.8	170.9	258.6	7.5
	200 STD	233.3	226.2	11.5	218.2	243.9	10.0	202.5	264.0	8.6	186.3	286.5	7.4
	225 STD	255.8	248.4	11.5	239.4	267.9	10.0	222.3	290.0	8.6	203.1	311.4	7.4
	250 STD	280.6	272.3	11.5	262.5	293.6	10.0	243.7	317.5	8.7	218.2	330.7	7.5
	275 STD	317.6	298.5	11.8	297.0	322.4	10.3	275.9	349.4	8.9	250.8	373.1	7.6
	300 STD	354.0	343.1	11.5	331.0	369.4	10.0	307.3	399.3	8.7	278.7	424.3	7.4
	350 STD	401.7	391.1	11.4	375.7	420.8	10.0	348.8	454.3	8.7	307.4	462.5	7.5

Notes:

1. Ratings based on sea level altitude and evaporator fouling factor of 0.00010.
2. Consult Trane representative for performance at temperatures outside of the ranges shown.
3. kW input is for compressors only.
4. EER = Energy Efficiency Ratio (Btu/watt-hour). Power inputs include compressors, condenser fans and control power.
5. Ratings are based on an evaporator temperature drop of 10°F and the standard evaporator pass arrangement.
6. Ambient temperatures 115°F and greater reflect the high ambient condenser option.
7. Interpolation between points is permissible. Extrapolation is not permitted.
8. Rated in accordance with ARI Standard 550/590.



Performance Data

Full Load Performance

Tab. 07a - 60 Hz high efficiency machines in English units

Evaporator Leaving Water Temperature (F)	Unit Size Model RTAC	Condenser Entering Air Temperature (F)											
		85			95			105			115		
		Tons	Input kW	EER	Tons	Input kW	EER	Tons	Input kW	EER	Tons	Input kW	EER
40	140 HIGH	142.8	134.5	11.4	133.3	146.1	9.9	123.3	159.3	8.5	113.1	174.2	7.2
	155 HIGH	155.9	145.9	11.5	145.6	158.7	10.0	134.9	173.3	8.5	124.0	189.6	7.2
	170 HIGH	169.9	157.6	11.6	158.7	171.7	10.0	147.2	187.5	8.6	135.4	205.3	7.3
	185 HIGH	185.7	176.5	11.3	173.7	191.5	9.9	161.3	208.7	8.5	148.5	228.0	7.2
	200 HIGH	202.5	196.0	11.2	189.5	212.1	9.8	176.0	230.5	8.4	162.1	251.4	7.2
	225 HIGH	221.9	216.0	11.2	208.0	233.6	9.8	193.5	253.7	8.5	178.5	276.5	7.2
	250 HIGH	240.9	235.6	11.1	226.0	254.9	9.7	210.5	276.9	8.4	194.4	301.8	7.2
	275 HIGH	274.8	257.8	11.6	257.1	279.7	10.1	238.7	304.6	8.7	219.9	332.7	7.4
300 HIGH	306.4	296.7	11.2	286.9	320.6	9.8	266.7	348.0	8.5	245.8	379.1	7.2	
42	140 HIGH	148.4	137.3	11.7	138.5	149.0	10.1	128.3	162.3	8.7	117.7	177.3	7.4
	155 HIGH	162.0	148.9	11.7	151.3	161.8	10.2	140.3	176.4	8.7	129.0	192.8	7.4
	170 HIGH	176.4	160.9	11.8	164.9	175.0	10.3	153.1	190.9	8.8	140.9	208.7	7.5
	185 HIGH	192.7	180.2	11.6	180.3	195.3	10.1	167.6	212.6	8.7	154.4	232.0	7.4
	200 HIGH	210.2	200.3	11.4	196.8	216.5	9.9	182.8	235.0	8.6	168.4	255.9	7.3
	225 HIGH	230.2	220.9	11.4	215.9	238.6	10.0	200.9	258.9	8.6	185.4	281.8	7.4
	250 HIGH	249.9	241.1	11.3	234.5	260.5	9.9	218.5	282.6	8.6	201.8	307.7	7.3
	275 HIGH	285.3	263.3	11.8	267.0	285.3	10.3	248.1	310.3	8.8	228.6	338.5	7.5
300 HIGH	317.9	303.2	11.4	297.8	327.2	10.0	276.9	354.8	8.7	255.3	386.0	7.4	
44	140 HIGH	154.1	140.1	11.9	143.9	151.9	10.3	133.3	165.3	8.9	122.4	180.4	7.5
	155 HIGH	168.1	151.9	11.9	157.1	164.9	10.4	145.8	179.6	8.9	134.1	196.1	7.6
	170 HIGH	183.1	164.2	12.0	171.2	178.3	10.5	159.0	194.4	9.0	146.5	212.3	7.7
	185 HIGH	199.9	184.0	11.8	187.1	199.2	10.3	173.9	216.6	8.9	160.4	236.1	7.5
	200 HIGH	217.9	204.7	11.6	204.1	221.0	10.1	189.7	239.6	8.8	174.9	260.6	7.5
	225 HIGH	238.7	225.9	11.6	223.9	243.7	10.2	208.4	264.1	8.8	192.4	287.2	7.5
	250 HIGH	259.2	246.7	11.5	243.2	266.2	10.1	226.6	288.5	8.7	209.3	313.7	7.5
	275 HIGH	296.0	268.9	12.0	277.1	291.0	10.5	257.6	316.1	9.0	237.5	344.4	7.7
300 HIGH	329.6	309.9	11.6	308.8	334.1	10.2	287.3	361.8	8.8	265.0	393.1	7.5	

Notes:

1. Ratings based on sea level altitude and evaporator fouling factor of 0.00010.
2. Consult Trane representative for performance at temperatures outside of the ranges shown.
3. kW input is for compressors only.
4. EER = Energy Efficiency Ratio (Btu/watt-hour). Power inputs include compressors, condenser fans and control power.
5. Ratings are based on an evaporator temperature drop of 10°F and the standard evaporator pass arrangement.
6. Ambient temperatures 115°F and greater reflect the high ambient condenser option.
7. Interpolation between points is permissible. Extrapolation is not permitted.
8. Rated in accordance with ARI Standard 550/590.



Performance Data

Full Load Performance

Tab. 07b - 60 Hz high efficiency machines in English units (Continued)

Evaporator Leaving Water Temperature (F)	Unit Size Model RTAC	Condenser Entering Air Temperature (F)											
		85			95			105			115		
		Tons	Input kW	EER	Tons	Input kW	EER	Tons	Input kW	EER	Tons	Input kW	EER
46	140 HIGH	159.9	143.1	12.1	149.4	154.9	10.5	138.5	168.4	9.1	127.2	183.5	7.7
	155 HIGH	174.3	155.1	12.2	163.0	168.1	10.6	151.4	182.9	9.1	139.4	199.5	7.8
	170 HIGH	189.8	167.6	12.3	177.6	181.8	10.7	165.1	197.9	9.2	152.2	215.9	7.8
	185 HIGH	207.1	187.9	12.0	194.0	203.2	10.5	180.4	220.6	9.0	166.4	240.2	7.7
	200 HIGH	225.8	209.2	11.8	211.5	225.5	10.3	196.7	244.2	8.9	181.4	265.3	7.6
	225 HIGH	247.4	231.1	11.8	232.0	249.0	10.3	216.1	269.5	8.9	199.5	292.6	7.7
	250 HIGH	268.6	252.5	11.7	252.1	272.1	10.2	234.8	294.6	8.9	216.9	319.8	7.6
	275 HIGH	306.8	274.7	12.2	287.3	296.8	10.7	267.2	322.1	9.2	246.6	350.5	7.9
48	300 HIGH	341.5	316.8	11.8	320.1	341.1	10.4	297.8	368.9	9.0	274.8	400.3	7.7
	140 HIGH	165.7	146.1	12.3	154.9	158.0	10.7	143.7	171.5	9.2	132.1	186.7	7.9
	155 HIGH	180.7	158.3	12.4	169.1	171.4	10.8	157.0	186.3	9.3	144.7	202.9	7.9
	170 HIGH	196.7	171.0	12.5	184.2	185.3	10.9	171.3	201.5	9.4	158.0	219.5	8.0
	185 HIGH	214.5	191.9	12.2	201.0	207.3	10.6	187.0	224.8	9.2	172.6	244.4	7.9
	200 HIGH	233.8	213.9	11.9	219.1	230.2	10.5	203.8	249.0	9.1	188.0	270.2	7.8
	225 HIGH	256.2	236.4	12.0	240.3	254.4	10.5	223.8	275.0	9.1	206.7	298.2	7.8
	250 HIGH	278.1	258.4	11.8	261.0	278.2	10.4	243.2	300.7	9.0	224.6	326.1	7.7
50	275 HIGH	317.9	280.5	12.4	297.8	302.8	10.8	277.0	328.1	9.4	255.8	356.6	8.0
	300 HIGH	353.6	323.9	12.0	331.5	348.2	10.5	308.5	376.1	9.1	284.8	407.7	7.8
	140 HIGH	171.7	149.2	12.5	160.5	161.2	10.9	149.0	174.7	9.4	137.0	189.9	8.0
	155 HIGH	187.1	161.6	12.6	175.2	174.8	11.0	162.8	189.7	9.5	150.0	206.3	8.1
	170 HIGH	203.7	174.5	12.7	190.8	188.9	11.1	177.5	205.1	9.6	163.9	223.2	8.2
	185 HIGH	222.0	196.0	12.4	208.1	211.4	10.8	193.7	229.0	9.4	178.9	248.7	8.0
	200 HIGH	242.0	218.6	12.1	226.8	235.0	10.6	211.0	253.8	9.2	194.7	275.1	7.9
	225 HIGH	265.1	241.8	12.1	248.7	259.9	10.6	231.7	280.6	9.2	214.0	303.9	7.9
50	250 HIGH	287.8	264.5	12.0	270.1	284.4	10.5	251.7	307.0	9.1	232.4	332.4	7.9
	275 HIGH	329.1	286.6	12.6	308.4	308.9	11.0	287.0	334.3	9.6	265.1	362.8	8.2
	300 HIGH	365.9	331.1	12.2	343.0	355.5	10.7	319.3	383.5	9.3	294.9	415.2	8.0

Notes:

1. Ratings based on sea level altitude and evaporator fouling factor of 0.00010.
2. Consult Trane representative for performance at temperatures outside of the ranges shown.
3. kW input is for compressors only.
4. EER = Energy Efficiency Ratio (Btu/watt-hour). Power inputs include compressors, condenser fans and control power.
5. Ratings are based on an evaporator temperature drop of 10°F and the standard evaporator pass arrangement.
6. Ambient temperatures 115°F and greater reflect the high ambient condenser option.
7. Interpolation between points is permissible. Extrapolation is not permitted.
8. Rated in accordance with ARI Standard 550/590.



Performance Data

Full Load Performance

Tab. 08 – 60 Hz standard efficiency machines in SI units

Evaporator Leaving Water Temperature (C)	Unit Size Model RTAC RTAC	Condenser Entering Air Temperature (C)											
		30			35			40			45		
		KW. cooling	Input kW	COP	KW. cooling	Input kW	COP	KW. cooling	Input kW	COP	KW. cooling	Input kW	COP
5	140 STD	490.8	142.6	3.2	459.9	153.9	2.8	428.3	166.5	2.4	395.9	180.5	2.1
	155 STD	538.7	155.2	3.2	505.6	167.5	2.8	471.1	181.3	2.4	436.3	196.5	2.1
	170 STD	588.9	168.1	3.2	553.4	181.6	2.8	516.9	196.6	2.4	479.6	213.1	2.1
	185 STD	642.4	186.9	3.2	603.7	201.5	2.8	564.0	217.7	2.4	523.2	235.7	2.1
	200 STD	699.3	206.5	3.1	657.5	222.1	2.7	614.3	239.6	2.4	569.6	259.1	2.1
	225 STD	766.5	226.1	3.1	721.5	243.3	2.8	675.1	262.5	2.4	626.9	283.9	2.1
	250 STD	840.0	247.0	3.1	791.1	265.6	2.8	740.1	286.5	2.4	687.7	309.7	2.1
	275 STD	950.0	273.3	3.2	893.1	294.4	2.8	834.7	318.0	2.4	774.9	344.2	2.1
	300 STD	1061.1	313.0	3.1	998.2	336.2	2.8	932.8	362.3	2.4	865.6	391.3	2.1
	350 STD	1203.2	354.9	3.1	1132.9	381.0	2.8	1059.7	410.4	2.4	984.5	443.0	2.1
7	140 STD	523.9	148.1	3.3	491.5	159.6	2.9	457.8	172.3	2.5	423.3	186.4	2.1
	155 STD	574.9	161.2	3.3	539.7	173.7	2.9	503.8	187.6	2.5	466.6	202.9	2.2
	170 STD	628.0	174.5	3.3	590.7	188.1	2.9	552.4	203.3	2.5	513.0	219.9	2.2
	185 STD	684.6	194.2	3.2	643.8	208.9	2.9	601.9	225.3	2.5	559.0	243.5	2.2
	200 STD	745.0	214.8	3.2	700.7	230.6	2.8	654.7	248.3	2.5	607.9	268.0	2.1
	225 STD	816.4	235.5	3.2	769.0	252.8	2.8	719.4	272.3	2.5	668.4	293.9	2.1
	250 STD	895.2	257.5	3.2	843.1	276.4	2.8	789.0	297.6	2.5	732.7	321.0	2.2
	275 STD	1012.6	283.9	3.3	952.5	305.3	2.9	891.0	329.2	2.5	827.7	355.5	2.2
	300 STD	1130.0	325.6	3.2	1063.2	349.1	2.8	994.3	375.5	2.5	923.3	404.8	2.1
	350 STD	1281.9	370.0	3.2	1206.7	396.4	2.8	1129.0	426.1	2.5	1049.2	459.0	2.2
9	140 STD	558.0	153.9	3.4	523.5	165.5	3.0	488.0	178.4	2.6	451.5	162.6	2.2
	155 STD	612.1	167.4	3.4	575.2	180.1	3.0	536.9	194.1	2.6	497.9	209.5	2.2
	170 STD	668.4	181.2	3.4	628.7	194.9	3.0	588.2	210.2	2.6	547.1	226.9	2.3
	185 STD	727.8	201.8	3.3	684.9	216.7	2.9	640.6	233.3	2.6	595.6	251.6	2.2
	200 STD	791.5	223.5	3.3	744.7	239.4	2.9	696.5	257.3	2.5	646.6	277.2	2.2
	225 STD	867.8	245.2	3.3	817.1	262.8	2.9	764.7	282.5	2.5	710.6	304.3	2.2
	250 STD	951.8	268.6	3.3	896.2	287.8	2.9	838.6	309.1	2.5	778.8	332.7	2.2
	275 STD	1077.0	295.1	3.4	1013.3	316.6	3.0	948.3	340.7	2.6	881.8	367.2	2.3
	300 STD	1200.7	338.8	3.3	1130.0	362.5	2.9	1056.9	389.1	2.5	982.0	418.7	2.2
	350 STD	1362.5	385.8	3.3	1282.6	412.5	2.9	1200.0	442.4	2.5	1114.9	475.6	2.2

Notes:

1. Ratings based on sea level altitude and evaporator fouling factor of 0.0176.
2. Consult Trane representative for performance at temperatures outside of the ranges shown.
3. kW input is for compressors only.
4. COP = Coefficient of Performance (kW_o/kW_i). Power inputs include compressors, condenser fans and control power.
5. Ratings are based on an evaporator temperature drop of 5.6°C and the standard evaporator pass arrangement.
6. Ambient temperatures 40°C and greater reflect the high ambient condenser option.
7. Interpolation between points is permissible. Extrapolation is not permitted.
8. Rated in accordance with ARI Standard 550/590.



Performance Data

Full Load Performance

Tab. 09 – 60 Hz high efficiency machines in SI units

Evaporator Leaving Water Temperature (C)	Unit Size Model RTAC	Temperatura en la entrada de aire en el condensador (C)											
		30			35			40			45		
		KW. cooling	Input kW	COP	KW. cooling	Input kW	COP	KW. cooling	Input kW	COP	KW. cooling	Input kW	COP
5	RTAC	508.8	137.0	3.3	477.8	147.5	2.9	445.8	159.4	2.6	413.1	172.6	2.2
	155 HIGH	555.2	148.6	3.4	522.1	160.2	3.0	487.7	173.3	2.6	452.5	187.8	2.2
	170 HIGH	604.8	160.6	3.4	568.9	173.3	3.0	532.0	187.5	2.6	494.4	203.3	2.2
	185 HIGH	661.0	179.7	3.3	622.3	193.4	2.9	582.6	208.8	2.6	541.8	226.0	2.2
	200 HIGH	720.8	199.7	3.3	678.9	214.3	2.9	635.7	230.8	2.5	591.0	249.3	2.2
	225 HIGH	790.1	220.1	3.3	745.0	236.1	2.9	698.6	254.2	2.5	650.5	274.4	2.2
	250 HIGH	857.6	240.2	3.2	809.7	257.7	2.9	759.8	277.4	2.5	708.1	299.5	2.2
	275 HIGH	978.5	262.6	3.4	921.2	282.5	3.0	862.5	304.8	2.6	802.0	329.7	2.3
	300 HIGH	1090.7	302.2	3.3	1027.7	323.9	2.9	963.0	348.5	2.6	895.9	376.0	2.2
7	140 HIGH	544.3	142.1	3.5	511.6	152.8	3.1	478.2	164.8	2.7	443.4	178.1	2.3
	155 HIGH	593.9	154.1	3.5	558.7	165.9	3.1	522.5	179.1	2.7	485.6	193.7	2.3
	170 HIGH	646.6	166.5	3.5	608.6	179.4	3.1	569.9	193.7	2.7	530.2	209.6	2.3
	185 HIGH	706.0	186.6	3.4	665.2	200.4	3.0	623.0	216.0	2.7	580.1	233.2	2.3
	200 HIGH	769.7	207.6	3.4	725.4	222.3	3.0	679.6	239.0	2.6	632.5	257.6	2.3
	225 HIGH	843.5	229.1	3.4	795.7	245.3	3.0	746.5	263.6	2.6	695.5	284.0	2.3
	250 HIGH	915.6	250.3	3.3	864.6	268.0	3.0	811.5	288.0	2.6	756.3	310.3	2.3
	275 HIGH	1045.7	272.7	3.5	985.2	292.7	3.1	923.0	315.3	2.7	859.0	340.3	2.3
	300 HIGH	1164.2	314.3	3.4	1097.7	336.2	3.0	1028.8	361.0	2.6	958.1	388.7	2.3
9	140 HIGH	581.2	147.5	3.6	546.7	158.3	3.2	511.2	170.4	2.8	474.3	183.9	2.4
	155 HIGH	633.6	159.9	3.6	596.7	171.8	3.2	558.3	185.0	2.8	519.3	199.8	2.4
	170 HIGH	689.8	172.7	3.6	649.8	185.7	3.2	609.0	200.1	2.8	567.1	216.1	2.4
	185 HIGH	752.4	193.8	3.5	709.2	207.7	3.1	664.9	223.3	2.7	619.5	240.7	2.4
	200 HIGH	819.9	215.9	3.5	773.2	230.7	3.1	724.7	247.5	2.7	674.7	266.2	2.4
	225 HIGH	898.3	238.6	3.5	848.1	254.9	3.1	795.7	273.4	2.7	741.5	293.9	2.4
	250 HIGH	975.3	260.9	3.4	921.2	278.8	3.0	864.6	299.0	2.7	805.9	321.4	2.3
	275 HIGH	1114.6	283.3	3.6	1050.9	303.4	3.2	985.2	326.1	2.8	917.7	351.3	2.4
	300 HIGH	1240.1	326.9	3.5	1169.4	348.9	3.1	1096.6	373.9	2.7	1021.8	401.8	2.4

Notes:

1. Ratings based on sea level altitude and evaporator fouling factor of 0.0176.
2. Consult Trane representative for performance at temperatures outside of the ranges shown.
3. kW input is for compressors only.
4. COP = Coefficient of Performance (kW_o/kW_i). Power inputs include compressors, condenser fans and control power.
5. Ratings are based on an evaporator temperature drop of 5.6°C and the standard evaporator pass arrangement.
6. Ambient temperatures 40°C and greater reflect the high ambient condenser option.
7. Interpolation between points is permissible. Extrapolation is not permitted.
8. Rated in accordance with ARI Standard 550/590.



Performance Data

Full Load Performance

Tab. 10a – 50 Hz standard efficiency machines in English units

Evaporator Leaving Water Temperature (F)	Unit Size Model RTAC	Condenser Entering Air Temperature (F)											
		85			95			105			115		
		Tons	Input kW	EER	Tons	Input kW	EER	Tons	Input kW	EER	Tons	Input kW	EER
40	RTAC	134.2	144.4	10.6	124.5	158.0	9.0	114.5	173.1	7.6	104.3	189.8	6.4
	155 STD	146.7	159.3	10.5	136.1	173.7	9.0	125.3	189.9	7.6	114.2	207.8	6.4
	170 STD	159.8	174.7	10.4	148.4	190.1	8.9	136.7	207.4	7.6	124.7	226.6	6.4
	185 STD	176.5	190.4	10.6	164.2	207.0	9.1	151.6	225.7	7.7	138.6	246.5	6.5
	200 STD	194.3	206.8	10.7	181.1	224.8	9.2	167.4	244.9	7.9	153.3	267.2	6.6
	250 STD	233.2	248.3	10.7	217.0	270.9	9.2	200.3	296.1	7.8	183.1	323.9	6.5
	275 STD	260.0	279.9	10.6	241.9	304.2	9.1	223.3	331.4	7.8	204.2	361.7	6.5
	300 STD	295.0	313.3	10.7	275.0	340.0	9.3	254.4	370.1	7.9	230.9	398.6	6.7
42	350 STD	326.4	354.5	10.5	303.5	385.4	9.0	279.9	420.0	7.7	254.5	456.0	6.5
	140 STD	139.1	147.6	10.8	129.0	161.3	9.2	118.8	176.5	7.8	107.1	190.7	6.5
	155 STD	151.9	162.9	10.7	141.0	177.4	9.1	129.9	193.7	7.7	116.7	207.9	6.5
	170 STD	165.4	178.7	10.6	153.7	194.2	9.1	141.6	211.6	7.7	127.5	227.1	6.5
	185 STD	182.6	194.7	10.7	170.0	211.6	9.2	157.0	230.5	7.9	140.9	245.5	6.6
	200 STD	201.1	211.6	10.9	187.5	229.8	9.4	173.3	250.1	8.0	154.9	264.4	6.8
	250 STD	241.5	253.9	10.9	224.7	276.6	9.3	207.5	302.0	7.9	185.9	321.7	6.7
	275 STD	269.1	286.4	10.7	250.4	310.8	9.2	231.2	338.3	7.9	206.6	358.2	6.7
44	300 STD	305.3	320.6	10.9	284.7	347.7	9.4	263.4	378.0	8.0	232.0	391.7	6.8
	350 STD	337.6	362.6	10.6	314.0	3393.7	9.2	289.7	428.6	7.8	256.5	448.8	6.6
	140 STD	144.0	150.8	10.9	133.7	164.6	9.3	123.1	180.0	7.9	108.1	187.6	6.7
	155 STD	157.3	166.5	10.8	146.0	181.2	9.3	134.5	197.6	7.9	118.0	205.1	6.6
	170 STD	171.1	182.8	10.7	159.0	198.4	9.2	146.6	216.0	7.8	128.5	223.4	6.6
	185 STD	188.9	199.2	10.8	175.9	216.2	9.3	162.5	235.3	8.0	142.5	242.7	6.8
	200 STD	208.0	216.6	11.0	193.9	234.9	9.5	179.4	255.5	8.1	155.6	259.4	6.9
	250 STD	249.8	259.5	11.0	232.6	282.5	9.5	214.8	308.1	8.0	187.6	316.8	6.8
275 STD	278.3	293.0	10.9	259.0	317.7	9.4	239.2	345.3	8.0	207.8	351.8	6.8	
300 STD	315.7	328.1	11.0	294.4	355.5	9.5	272.4	386.1	8.1	234.1	386.4	7.0	
350 STD	349.0	370.8	10.8	324.6	402.2	9.3	299.6	437.3	7.9	258.1	440.8	6.8	

Notes:

1. Ratings based on sea level altitude and evaporator fouling factor of 0.00010.
2. Consult Trane representative for performance at temperatures outside of the ranges shown.
3. kW input is for compressors only.
4. EER = Energy Efficiency Ratio (Btu/watt-hour). Power inputs include compressors, condenser fans and control power.
5. Ratings are based on an evaporator temperature drop of 10°F and the standard evaporator pass arrangement.
6. Ambient temperatures 115°F and greater reflect the high ambient condenser option.
7. Interpolation between points is permissible. Extrapolation is not permitted.
8. Rated in accordance with ARI Standard 550/590.



Performance Data

Full Load Performance

Tab. 10b - 50 Hz standard efficiency machines in English units (Continued)

Evaporator Leaving Water Temperature (F)	Unit Size Model RTAC	Condenser Entering Air Temperature (F)											
		85			95			105			115		
		Tons	Input kW	EER	Tons	Input kW	EER	Tons	Input kW	EER	Tons	Input kW	EER
46	RTAC	149.0	154.1	11.1	138.4	168.0	9.5	127.5	183.5	8.0	109.0	184.2	6.8
	155 STD	162.6	170.3	10.9	151.1	185.1	9.4	139.2	201.6	8.0	119.2	202.0	6.8
	170 STD	176.8	187.0	10.8	164.3	202.7	9.3	151.6	220.4	7.9	130.0	220.5	6.8
	185 STD	195.2	203.8	11.0	181.8	221.0	9.5	168.0	240.2	8.1	143.2	237.9	6.9
	200 STD	215.0	221.6	11.1	200.4	240.2	9.6	185.4	261.0	8.2	157.0	255.5	7.1
	250 STD	258.3	265.3	11.2	240.5	288.5	9.6	222.2	314.3	8.2	189.0	311.4	7.0
	275 STD	287.6	299.7	11.0	267.7	324.6	9.5	247.3	352.5	8.1	209.9	346.9	7.0
	300 STD	326.2	335.8	11.1	304.2	363.5	9.6	281.6	394.5	8.2	236.0	380.3	7.2
	350 STD	360.5	379.3	10.9	335.4	410.8	9.4	309.6	446.1	8.0	260.7	434.6	6.9
	48	140 STD	154.0	157.4	11.2	143.1	171.5	9.6	131.9	187.1	8.2	109.7	180.4
155 STD		168.1	174.1	11.1	156.2	189.0	9.5	144.0	205.6	8.1	120.2	198.6	7.0
170 STD		182.6	191.2	10.9	169.8	207.1	9.4	156.6	224.8	8.0	130.6	215.9	7.0
185 STD		201.6	208.5	11.1	187.8	225.8	9.6	173.5	245.2	8.2	144.5	234.1	7.1
200 STD		222.0	226.8	11.2	207.0	245.6	9.7	191.6	266.6	8.3	158.3	251.1	7.3
250 STD		266.9	271.2	11.3	248.5	294.6	9.7	229.7	320.7	8.3	190.3	305.3	7.2
275 STD		297.0	306.7	11.1	276.5	331.8	9.6	255.5	359.9	8.2	210.6	339.0	7.2
300 STD		336.8	343.7	11.2	314.2	371.7	9.7	286.9	394.9	8.4	237.7	373.3	7.3
350 STD		372.1	387.9	11.0	346.2	419.6	9.5	317.0	449.5	8.1	263.1	427.7	7.1
50		140 STD	159.1	160.9	11.4	147.9	175.0	9.7	134.3	186.5	8.3	111.0	177.7
	155 STD ^r	173.6	178.0	11.2	161.3	193.0	9.6	146.1	204.1	8.3	121.8	196.2	7.2
	170 STD	188.4	195.6	11.1	175.2	211.5	9.5	159.1	223.7	8.2	131.8	212.3	7.2
	185 STD	208.0	213.3	11.2	193.8	230.8	9.7	175.3	242.2	8.4	145.6	229.8	7.3
	200 STD	229.1	232.1	11.3	213.7	251.1	9.8	192.5	261.3	8.5	159.7	246.8	7.5
	250 STD	275.6	277.3	11.4	256.7	300.9	9.8	231.7	315.6	8.5	192.5	301.0	7.4
	275 STD	306.5	313.8	11.2	285.4	339.0	9.7	257.0	353.1	8.4	212.8	334.2	7.3
	300 STD	347.6	351.9	11.3	324.3	380.1	9.8	288.1	386.4	8.6	240.5	369.0	7.5
	350 STD	383.8	396.7	11.1	357.2	428.6	9.6	319.1	441.0	8.4	264.9	420.0	7.3

Notes:

1. Ratings based on sea level altitude and evaporator fouling factor of 0.00010.
2. Consult Trane representative for performance at temperatures outside of the ranges shown.
3. kW input is for compressors only.
4. EER = Energy Efficiency Ratio (Btu/watt-hour). Power inputs include compressors, condenser fans and control power.
5. Ratings are based on an evaporator temperature drop of 10°F and the standard evaporator pass arrangement.
6. Ambient temperatures 115°F and greater reflect the high ambient condenser option.
7. Interpolation between points is permissible. Extrapolation is not permitted.
8. Rated in accordance with ARI Standard 550/590.



Performance Data

Full Load Performance

Tab. 11a – 50 Hz high efficiency machines in English units

Evaporator Leaving Water Temperature (F)	Unit Size Model RTAC	Condenser Entering Air Temperature (F)											
		85			95			105			115		
		Tons	Input kW	EER	Tons	Input kW	EER	Tons	Input kW	EER	Tons	Input kW	EER
40	140 HIGH	140.0	137.2	11.5	130.3	149.9	9.8	120.2	164.2	8.3	110.0	180.0	7.0
	155 HIGH	152.2	151.3	11.3	141.6	164.9	9.7	130.8	180.2	8.3	119.6	197.2	6.9
	170 HIGH	165.0	166.0	11.2	153.6	180.4	9.6	141.8	196.7	8.2	129.7	214.9	6.9
	185 HIGH	182.7	181.9	11.3	170.5	197.6	9.8	157.8	215.3	8.4	144.8	235.0	7.1
	200 HIGH	201.4	198.5	11.5	188.3	215.4	9.9	174.6	234.4	8.5	160.4	255.6	7.2
	250 HIGH	240.8	242.2	11.3	224.3	263.8	9.7	207.2	288.0	8.2	189.7	314.8	6.9
	275 HIGH	269.3	267.5	11.4	251.2	390.2	9.8	232.4	315.9	8.4	213.2	344.6	7.1
	300 HIGH	304.9	300.4	11.5	285.1	325.5	10.0	264.5	353.8	8.6	243.3	385.5	7.3
	350 HIGH	337.2	337.2	11.3	314.2	366.0	9.7	290.5	398.7	8.3	266.2	435.2	7.0
42	140 HIGH	145.3	140.1	11.7	135.3	152.9	10.0	125.0	161.3	8.5	114.4	183.2	7.2
	155 HIGH	157.9	154.6	11.5	147.0	168.3	9.9	135.8	183.7	8.4	124.3	200.8	7.1
	170 HIGH	171.1	169.7	11.4	159.4	184.2	9.8	147.2	200.6	8.4	134.8	219.0	7.1
	185 HIGH	189.4	186.0	11.5	176.7	201.8	9.9	163.7	219.6	8.5	150.3	239.5	7.2
	200 HIGH	208.8	203.0	11.6	195.2	220.0	10.1	181.1	239.2	8.6	166.5	260.6	7.3
	250 HIGH	249.7	247.6	11.4	232.6	269.3	9.8	215.0	293.7	8.4	193.8	314.6	7.1
	275 HIGH	279.2	273.5	11.6	260.5	296.4	10.0	241.1	322.3	8.6	221.3	351.2	7.2
	300 HIGH	316.0	307.3	11.7	295.5	332.6	10.1	274.3	361.2	8.7	252.4	393.2	7.4
	350 HIGH	349.3	344.6	11.4	325.6	373.7	9.9	301.2	406.5	8.5	276.2	443.3	7.1
44	140 HIGH	150.7	143.0	11.9	140.4	155.9	10.2	129.8	170.4	8.7	118.9	186.4	7.3
	155 HIGH	163.6	157.9	11.7	152.4	171.7	10.1	140.9	187.2	8.6	129.1	204.5	7.2
	170 HIGH	177.3	173.5	11.5	165.2	188.1	10.0	152.7	204.6	8.5	139.8	223.0	7.2
	185 HIGH	196.1	190.2	11.7	183.1	206.1	10.1	169.7	224.0	8.7	155.8	244.1	7.3
	200 HIGH	216.3	207.6	11.8	202.2	224.8	10.2	187.6	244.2	8.8	172.6	265.8	7.5
	250 HIGH	258.7	253.1	11.6	241.1	275.0	10.0	222.9	299.6	8.5	195.6	310.0	7.2
	275 HIGH	289.2	279.7	11.7	269.9	302.8	10.2	249.9	328.8	8.7	229.4	357.9	7.4
	300 HIGH	327.2	314.3	11.8	306.1	339.9	10.3	284.2	368.8	8.8	261.6	401.0	7.5
	350 HIGH	361.7	352.3	11.6	337.2	381.5	10.0	312.1	414.5	8.6	286.3	451.4	7.3

Notes:

1. Ratings based on sea level altitude and evaporator fouling factor of 0.00010.
2. Consult Trane representative for performance at temperatures outside of the ranges shown.
3. kW input is for compressors only.
4. EER = Energy Efficiency Ratio (Btu/watt-hour). Power inputs include compressors, condenser fans and control power.
5. Ratings are based on an evaporator temperature drop of 10°F.
6. Ambient temperatures 115°F and greater reflect the high ambient condenser option.
7. Interpolation between points is permissible. Extrapolation is not permitted.
8. Rated in accordance with ARI Standard 550/590-98.



Performance Data

Full Load Performance

Tab. 11b - 50 Hz high efficiency machines in English units (Continued)

Evaporator Leaving Water Temperature (F)	Unit Size Model RTAC	Condenser Entering Air Temperature (F)											
		85			95			105			115		
		Tons	Input kW	EER	Tons	Input kW	EER	Tons	Input kW	EER	Tons	Input kW	EER
46	140 HIGH	156.2	146.0	12.1	145.6	159.1	10.4	134.6	173.6	8.9	123.4	189.7	7.5
	155 HIGH	169.5	161.4	11.9	158.0	175.2	10.2	146.1	190.8	8.7	133.9	208.2	7.4
	170 HIGH	183.6	177.4	11.7	171.1	192.1	10.1	158.2	208.7	8.7	145.0	227.2	7.3
	185 HIGH	203.0	194.4	11.8	189.6	210.5	10.3	175.7	228.6	8.8	161.5	248.7	7.5
	200 HIGH	223.9	212.4	12.0	209.4	229.7	10.4	194.3	249.3	8.9	178.8	271.1	7.6
	250 HIGH	267.8	258.7	11.8	249.6	280.8	10.2	230.9	305.6	8.7	197.1	304.7	7.4
	275 HIGH	299.4	286.1	11.9	279.4	309.3	10.3	258.8	335.5	8.9	237.7	364.8	7.5
	300 HIGH	338.7	321.6	12.0	316.8	347.4	10.4	294.3	376.5	9.0	271.0	409.1	7.6
	350 HIGH	374.2	360.1	11.8	349.0	389.5	10.2	323.1	422.7	8.7	296.5	459.7	7.4
48	140 HIGH	161.8	149.1	12.3	150.8	162.2	10.6	139.6	176.9	9.0	128.0	193.1	7.6
	155 HIGH	175.4	164.9	12.0	163.6	178.8	10.4	151.3	194.5	8.9	138.8	211.9	7.5
	170 HIGH	189.9	181.3	11.9	177.0	196.1	10.3	163.8	212.8	8.8	150.2	231.4	7.5
	185 HIGH	210.0	198.8	12.0	196.1	214.9	10.4	181.9	233.2	8.9	167.2	253.5	7.6
	200 HIGH	231.6	217.2	12.1	216.6	234.7	10.5	201.1	254.5	9.1	185.1	276.5	7.7
	250 HIGH	277.1	264.5	11.9	258.3	286.8	10.3	239.1	311.7	8.8	198.5	298.8	7.6
	275 HIGH	309.7	292.6	12.0	289.1	315.9	10.5	267.9	342.3	9.0	246.1	371.8	7.6
	300 HIGH	350.3	329.0	12.1	327.8	355.0	10.6	304.5	384.4	9.1	280.5	417.3	7.8
	350 HIGH	386.8	368.1	11.9	360.9	397.6	10.3	334.2	431.0	8.9	306.9	468.1	7.5
50	140 HIGH	167.4	152.3	12.5	156.2	165.4	10.7	144.6	180.2	9.2	132.7	196.5	7.8
	155 HIGH	181.4	168.4	12.2	169.2	182.5	10.6	156.7	198.2	9.0	143.8	215.7	7.7
	170 HIGH	196.3	185.3	12.0	183.1	200.2	10.4	169.4	217.0	8.9	155.4	235.6	7.6
	185 HIGH	217.0	203.2	12.1	202.8	219.5	10.5	188.1	237.9	9.1	173.0	258.4	7.7
	200 HIGH	239.4	222.2	12.2	223.9	239.8	10.7	208.0	259.8	9.2	189.7	278.4	7.8
	250 HIGH	286.5	270.4	12.1	267.1	292.9	10.4	242.3	309.0	9.0	199.6	292.2	7.8
	275 HIGH	320.1	299.2	12.2	298.9	322.7	10.6	277.1	349.3	9.1	253.5	376.5	7.8
	300 HIGH	362.1	336.6	12.3	338.8	362.8	10.7	314.8	392.5	9.2	283.2	411.9	7.9
	350 HIGH	399.6	376.2	12.1	373.0	405.9	10.5	345.5	439.4	9.0	317.4	476.7	7.7

Notes:

1. Ratings based on sea level altitude and evaporator fouling factor of 0.00010.
2. Consult Trane representative for performance at temperatures outside of the ranges shown.
3. kW input is for compressors only.
4. EER = Energy Efficiency Ratio (Btu/watt-hour). Power inputs include compressors, condenser fans and control power.
5. Ratings are based on an evaporator temperature drop of 10°F and the standard evaporator pass arrangement.
6. Ambient temperatures 115°F and greater reflect the high ambient condenser option.
7. Interpolation between points is permissible. Extrapolation is not permitted.
8. Rated in accordance with ARI Standard 550/590.



Performance Data

Full Load Performance

Tab. 12 – 50 Hz standard efficiency machines in SI units

Evaporator Leaving Water Temperature (C)	Unit Size Model RTAC	Condenser Entering Air Temperature (C)											
		85			95			105			115		
		KW cooling	Input kW	COP	KW. cooling	Input kW	COP	KW. cooling	Input kW	COP	KW. cooling	Input kW	COP
5	140 STD	477.1	147.3	3.1	445.8	159.6	2.7	413.8	173.2	2.3	381.1	188.0	2.0
	155 STD	521.1	162.4	3.1	487.3	175.6	2.7	452.5	190.1	2.3	417.0	206.0	2.0
	170 STD	567.5	178.2	3.0	530.9	192.2	2.6	493.7	207.7	2.3	455.3	224.8	2.0
	185 STD	629.9	194.1	3.1	587.5	209.3	2.7	547.1	226.1	2.3	505.6	244.6	2.0
	200 STD	690.5	210.9	3.1	648.0	227.3	2.7	604.1	245.4	2.4	558.7	265.3	2.0
	250 STD	828.7	253.2	3.1	776.7	273.8	2.7	722.9	296.4	2.3	668.0	321.2	2.0
	275 STD	924.0	285.4	3.1	865.6	307.5	2.7	805.9	332.0	2.3	744.7	358.9	2.0
	300 STD	1048.1	319.5	3.1	984.1	343.9	2.7	917.7	370.9	2.4	849.8	400.6	2.0
	350 STD	1159.2	361.5	3.1	1085.4	389.5	2.7	1009.8	420.6	2.3	932.4	454.9	2.0
7	140 STD	508.1	153.1	3.2	475.0	165.6	2.8	441.3	179.4	2.4	404.7	193.1	2.0
	155 STD	554.8	169.0	3.1	519.0	182.4	2.7	482.0	194.1	2.4	440.6	210.6	2.0
	170 STD	603.4	185.5	3.1	564.7	199.7	2.7	524.9	215.4	2.3	482.4	231.4	2.0
	185 STD	666.3	202.2	3.1	624.8	217.7	2.8	581.9	234.7	2.4	533.0	250.5	2.1
	200 STD	733.8	219.8	3.2	688.8	236.5	2.8	642.4	255.0	2.4	583.3	268.4	2.1
	250 STD	881.5	263.4	3.2	826.3	284.3	2.8	769.3	307.3	2.4	700.7	325.9	2.1
	275 STD	981.7	297.3	3.2	919.8	319.8	2.8	856.9	344.6	2.4	777.7	363.0	2.1
	300 STD	1113.5	333.0	3.2	1045.7	357.9	2.8	975.3	385.4	2.4	878.0	400.0	2.1
	350 STD	1230.6	376.4	3.1	1152.9	404.8	2.7	1072.7	436.2	2.4	969.7	457.2	2.0
9	140 STD	539.7	159.1	3.2	504.9	171.9	2.8	469.4	185.8	2.4	411.0	187.1	2.1
	155 STD	588.9	175.9	3.2	551.0	189.4	2.8	512.3	204.3	2.4	448.6	205.1	2.1
	170 STD	639.6	193.2	3.2	598.8	207.5	2.8	557.3	223.4	2.4	488.0	223.8	2.1
	185 STD	706.4	210.6	3.2	662.4	226.3	2.8	617.4	243.7	2.4	540.4	243.3	2.1
	200 STD	777.7	229.1	3.2	730.3	246.2	2.9	681.4	265.0	2.5	593.2	261.7	2.2
	250 STD	935.3	274.1	3.2	876.9	295.3	2.9	817.1	318.6	2.5	711.3	316.4	2.2
	275 STD	1040.4	309.8	3.2	975.3	332.5	2.8	908.5	357.7	2.5	788.3	352.3	2.2
	300 STD	1180.3	347.2	3.2	1108.2	372.6	2.9	1034.4	400.6	2.5	887.1	386.7	2.2
	350 STD	1303.4	391.8	3.2	1221.1	420.5	2.8	1137.1	452.3	2.4	983.8	443.8	2.1

Notes:

1. Ratings based on sea level altitude and evaporator fouling factor of 0.0176.
2. Consult Trane representative for performance at temperatures outside of the ranges shown.
3. kW input is for compressors only.
4. COP = Coefficient of Performance (kW_o/kW_i). Power inputs include compressors, condenser fans and control power.
5. Ratings are based on an evaporator temperature drop of 5.6°C and the standard evaporator pass arrangement.
6. Ambient temperatures 40°C and greater reflect the high ambient condenser option.
7. Interpolation between points is permissible. Extrapolation is not permitted.
8. Rated in accordance with ARI Standard 550/590.



Performance Data

Full Load Performance

Tab. 13 - 50 Hz high efficiency machines in SI units

Evaporator Leaving Water Temperature (C)	Unit Size Model RTAC	Condenser Entering Air Temperature (C)											
		85			95			105			115		
		KW. cooling	Input kW	COP	KW. cooling	Input kW	COP	KW. cooling	Input kW	COP	KW. cooling	Input kW	COP
5	140 HIGH	498.2	139.9	3.3	466.9	151.4	2.9	434.6	164.2	2.5	401.9	178.3	2.2
	155 HIGH	541.5	154.2	3.3	507.4	166.6	2.9	472.6	180.3	2.5	437.0	195.4	2.1
	170 HIGH	587.2	169.2	3.3	550.3	182.3	2.9	512.3	197.0	2.5	473.6	213.1	2.1
	185 HIGH	649.8	185.4	3.3	610.4	199.7	2.9	569.9	215.6	2.5	528.1	233.1	2.2
	200 HIGH	716.6	202.3	3.3	674.0	217.7	2.9	630.1	234.8	2.6	585.1	253.7	2.2
	250 HIGH	856.5	246.9	3.3	803.1	266.5	2.9	748.6	288.3	2.5	692.3	312.2	2.1
	275 HIGH	958.1	272.6	3.3	899.4	293.3	2.9	839.3	316.4	2.5	777.7	341.9	2.2
	300 HIGH	1084.3	306.2	3.4	1020.7	329.0	2.9	954.6	354.5	2.6	886.7	382.7	2.2
	350 HIGH	1199.0	343.6	3.3	1124.8	369.9	2.9	1048.8	399.2	2.5	971.1	431.6	2.2
7	140 HIGH	532.0	145.2	3.5	498.9	156.9	3.0	465.2	169.8	2.6	430.4	184.1	2.2
	155 HIGH	577.7	160.3	3.4	541.8	172.8	3.0	504.9	186.7	2.6	467.6	202.0	2.2
	170 HIGH	625.9	176.0	3.4	586.8	189.3	2.9	547.1	204.1	2.6	506.3	220.4	2.2
	185 HIGH	692.3	192.9	3.4	650.8	207.4	3.0	607.9	223.5	2.6	563.6	241.3	2.2
	200 HIGH	763.7	210.7	3.4	718.7	226.3	3.0	671.9	243.7	2.6	624.1	262.9	2.3
	250 HIGH	913.1	256.8	3.4	856.5	276.7	2.9	798.8	298.8	2.6	735.6	320.9	2.2
	275 HIGH	1021.1	283.8	3.4	958.8	304.7	3.0	895.2	328.1	2.6	830.1	353.9	2.3
	300 HIGH	1155.4	318.9	3.4	1087.5	342.1	3.0	1017.9	368.0	2.6	945.8	396.7	2.3
	350 HIGH	1276.3	357.4	3.4	1198.3	383.9	3.0	1118.1	413.5	2.6	1035.8	446.2	2.2
9	140 HIGH	567.1	150.7	3.6	532.3	162.5	3.1	496.5	175.7	2.7	459.9	190.0	2.3
	155 HIGH	615.0	166.5	3.5	577.0	179.2	3.1	538.3	193.2	2.7	498.9	208.7	2.3
	170 HIGH	665.6	183.1	3.4	624.4	196.5	3.0	582.6	211.5	2.6	539.4	227.9	2.3
	185 HIGH	735.9	200.8	3.5	692.0	215.4	3.1	646.6	231.7	2.7	600.2	249.8	2.3
	200 HIGH	811.8	219.4	3.5	764.0	235.2	3.1	715.2	252.9	2.7	664.5	272.5	2.3
	250 HIGH	971.1	267.2	3.5	911.4	287.4	3.0	850.5	309.8	2.6	742.9	309.6	2.3
	275 HIGH	1085.4	295.5	3.5	1020.0	316.6	3.1	952.8	340.2	2.7	883.9	366.3	2.3
	300 HIGH	1228.1	332.2	3.5	1156.4	355.8	3.1	1082.6	382.1	2.7	1006.6	411.3	2.4
	350 HIGH	1335.8	371.7	3.5	1273.1	398.5	3.0	1188.8	428.3	2.7	1102.3	461.3	2.3

Notes:

1. Ratings based on sea level altitude and evaporator fouling factor of 0.0176.
2. Consult Trane representative for performance at temperatures outside of the ranges shown.
3. kW input is for compressors only.
4. COP = Coefficient of Performance (kW_o/kW_i). Power inputs include compressors, condenser fans and control power.
5. Ratings are based on an evaporator temperature drop of 5.6°C and the standard evaporator pass arrangement.
6. Ambient temperatures 40°C and greater reflect the high ambient condenser option.
7. Interpolation between points is permissible. Extrapolation is not permitted.
8. Rated in accordance with ARI Standard 550/590.



Performance Data

Part Load Performance

Tab. 14 - ARI part-load performance for 60 Hz standard efficiency machines in English units

Unit Size	Full Load		IPLV
	Tons	EER	
140	138.2	9.7	13.5
155	151.9	9.8	13.6
170	166.2	9.9	13.9
185	181.2	9.7	13.7
200	197.2	9.6	13.3
225	216.4	9.6	13.4
250	237.2	9.6	13.6
275	268.0	9.8	13.3
300	299.2	9.6	13.3
350	339.6	9.6	13.1

Notes:

1. IPLV values are rated in accordance with ARI Standard 550/590.
2. EER and IPLV values include compressors, condenser fans and control kW.

Tab. 15 - ARI part-load performance for 60 Hz high efficiency machines in English units

Unit Size	Full Load		IPLV
	Tons	EER	
140	143.9	10.3	14.0
155	157.1	10.4	14.1
170	171.2	10.4	14.4
185	187.1	10.3	14.2
200	204.1	10.1	13.9
225	223.9	10.2	14.0
250	243.2	10.1	13.8
275	277.1	10.5	13.7
300	308.8	10.2	13.6

Tab. 16 - ARI part-load performance for 50 Hz standard efficiency machines in English units

Unit Size	Full Load		IPLV
	Tons	EER	
140	133.7	9.3	14.2
155	146.0	9.2	14.1
170	159.0	9.2	13.9
185	175.9	9.3	13.8
200	193.9	9.5	14.2
250	232.6	9.5	14.3
275	259.0	9.4	14.4
300	294.4	9.5	14.0
350	324.6	9.3	15.9

Notes:

1. IPLV values are rated in accordance with ARI Standard 550/590.
2. EER and IPLV values include compressors, condenser fans and control kW.

Tab. 17 - ARI part-load performance for 50 Hz high efficiency machines in English units

Unit Size	Full Load		IPLV
	Tons	EER	
140	140.4	10.2	15.0
155	152.4	10.1	14.9
170	165.2	14.7	14.7
185	183.1	10.1	14.6
200	202.2	10.2	14.9
250	241.1	10.0	14.3
275	269.9	10.2	14.9
300	306.1	10.3	14.5
350	337.2	10.0	16.1



Performance Data

Adjustment Factors

Fig. 18 - Evaporator water pressure drop, 2 compressor units, 2 pass evaporator

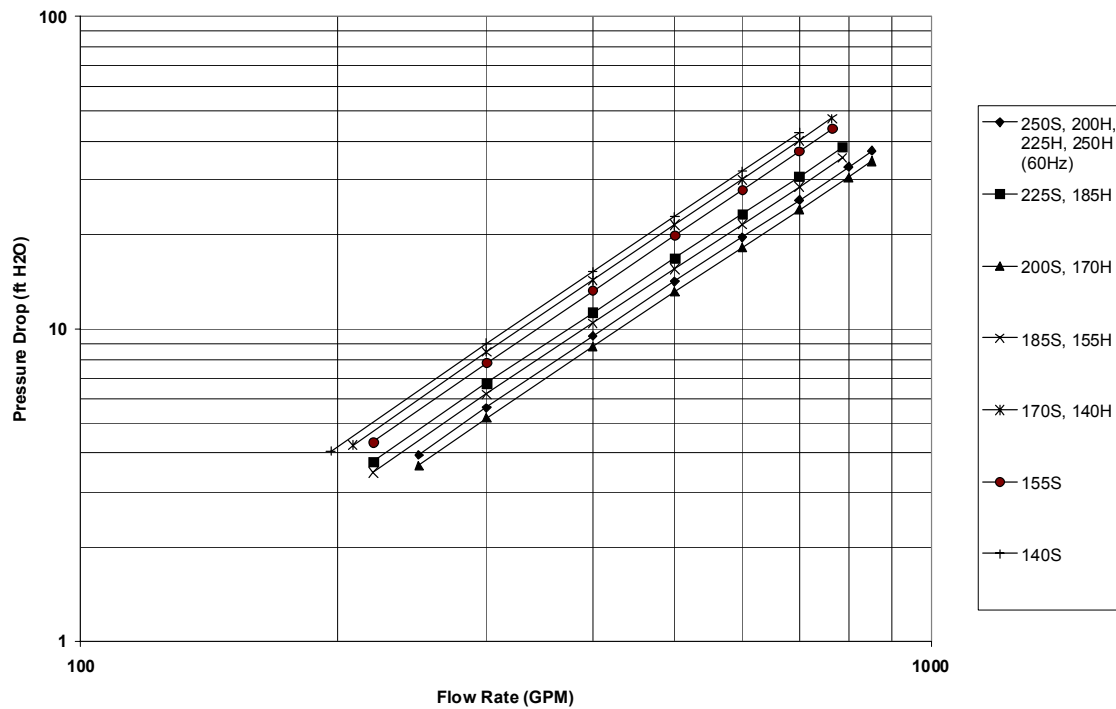
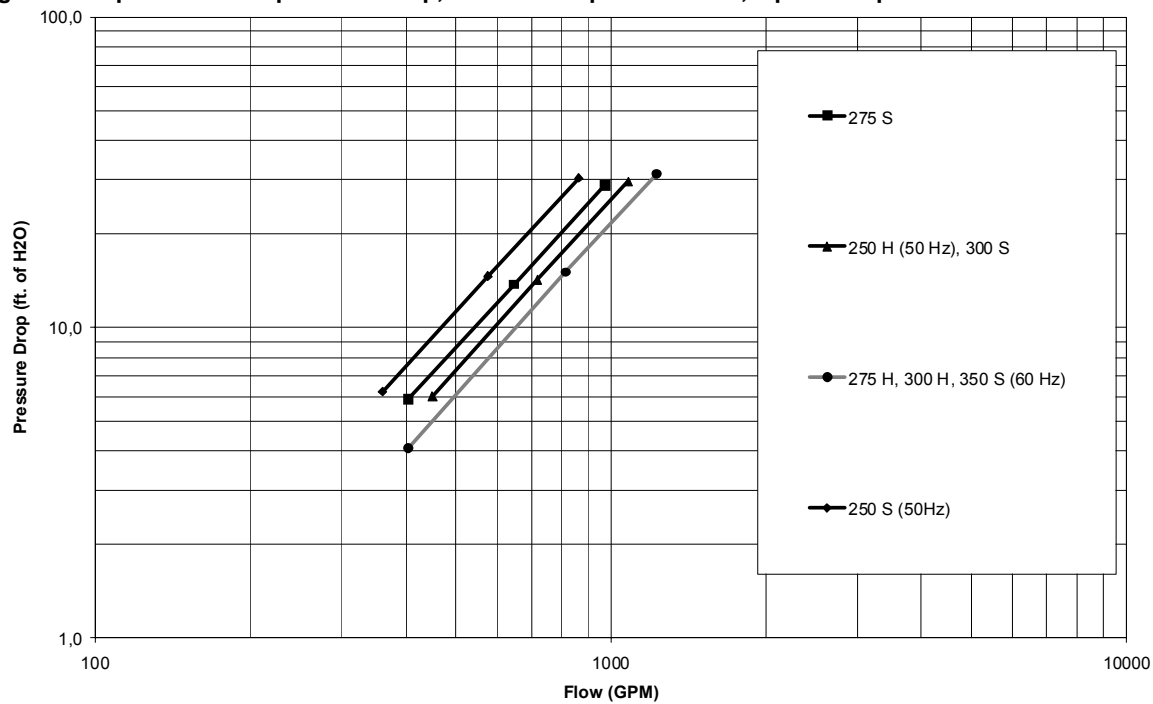

Fig. 19 - Evaporator water pressure drop, 3 and 4 compressor units, 2 pass evaporator





Electrical Data

Tab. 18 - Unit electrical data for standard efficiency at all ambient operation

Unit Size	Rated Voltage	# of Power Conns (1)	Unit Wiring				Qty.	Compressor (Each)			Fans (Each)			Control kW (7)
			MCA (3) Ckt1/Ckt2	Max. fuse HACR Breaker or MOP(11) Ckt1/Ckt2	Rec. Time rec. delay or RDE(4) Ckt1/Ckt2	RLA (5) Ckt1/Ckt2		XLRA (8) Ckt1/Ckt2	YLRA (8) Ckt1/Ckt2	Qty. Ckt1/Ckt2	kW	FLA		
RTAC 140	230/60/3	1	581	800	700	2	235-235	NA	427-427	8	0.75	4.6	0.83	
	380/60/3	1	348	450	400	2	142-142	801-801	260-260	8	0.75	2.7	0.83	
	440/60/3	1	288	400	350	2	118-118	652-652	212-212	8	0.75	2.2	0.83	
RTAC 155	230/60/3	1	641	800	800	2	278-235	NA	506-571	9	0.75	4.6	0.83	
	380/60/3	1	380	500	450	2	168-142	973-801	316-260	9	0.75	2.7	0.83	
	440/60/3	1	317	450	400	2	139-118	774-652	252-212	9	0.75	2.2	0.83	
RTAC 170	230/60/3	1	691	800	800	2	278-278	NA	506-506	10	0.75	4.6	0.83	
	380/60/3	1	413	500	500	2	168-168	973-973	316-316	10	0.75	2.7	0.83	
	440/60/3	1	341	450	400	2	139-139	774-774	252-252	10	0.75	2.2	0.83	
RTAC 185	230/60/3	1	770	1000	1000	2	336-278	NA	571-506	11	0.75	4.6	0.83	
	380/60/3	1	460	600	600	2	203-168	1060-973	345-316	11	0.75	2.7	0.83	
	440/60/3	1	380	500	450	2	168-139	878-774	285-252	11	0.75	2.2	0.83	
RTAC 200	230/60/3	1	834	1000	1000	2	336-336	NA	571-571	12	0.75	4.6	0.83	
	380/60/3	1	499	700	600	2	203-203	1060-1060	345-345	12	0.75	2.7	0.83	
	440/60/3	1	412	500	500	2	168-168	878-878	285-285	12	0.75	2.2	0.83	
RTAC 225	230/60/3	1	920	1200	1200	2	399-336	NA	691-571	13	0.75	4.6	0.83	
	380/60/3	1	551	700	700	2	242-203	1306-1060	424-345	13	0.75	2.7	0.83	
	440/60/3	1	454	600	600	2	200-168	1065-878	346-285	13	0.75	2.2	0.83	
RTAC 250	230/60/3	1	989	1200	1200	2	399-399	NA	691-691	14	0.75	4.6	0.83	
	380/60/3	1	594	800	700	2	242-242	1306-1306	424-424	14	0.75	2.7	0.83	
	440/60/3	1	489	600	600	2	200-200	1065-1065	346-346	14	0.75	2.2	0.83	
RTAC 275	230/60/3	2	681/459	800/700	800/600	3	278-278/336	NA	506-506/571	10/6	0.75	4.6	1.2	
	380/60/3	2	413/275	500/450	500/350	3	168-168/203	973-973/1060	316-316/345	10/6	0.75	2.7	1.2	
	440/60/3	2	341/227	450/350	400/300	3	139-139/168	774-774/878	252-252/285	10/6	0.75	2.2	1.2	
RTAC 300	230/60/3	2	834/459	1000/700	1000/600	3	336-336/336	NA	571-571/571	12/6	0.75	4.6	1.2	
	380/60/3	2	499/275	700/450	600/350	3	203-203/203	1060-1060/1060	345-345/345	12/6	0.75	2.7	1.2	
	440/60/3	2	412/227	500/350	500/300	3	168-168/168	878-878/878	285-285/285	12/6	0.75	2.2	1.2	
RTAC 350	230/60/3	2	989/459	1200/700	1200/600	3	399-399/336	NA	691-691/571	14/6	0.75	4.6	1.2	
	380/60/3	2	594/275	800/450	700/350	3	242-242/203	1306-1306/1060	424-424/345	14/6	0.75	2.7	1.2	
	440/60/3	2	490/227	600/350	600/300	3	200-200/168	1065-1065/973	346-346/285	14/6	0.75	2.2	1.2	

Notes:

- As standard, all units have single point power connection. Optional dual point power connections are available.
- Max Fuse or HACR type breaker = 225 percent of the largest compressor RLA plus 100 percent of the second compressor RLA, plus the sum of the condenser fan FLA per NEC 440-22.
Use FLA per circuit, NOT FLA for the entire unit).
- MCA - Minimum Circuit Ampacity - 125 percent of largest compressor RLA plus 100 percent of the second compressor RLA plus the sum of the condenser fans FLAs per NEC 440-33.
- RECOMMENDED TIME DELAY OR DUAL ELEMENT (RDE) FUSE SIZE: 150 percent of the largest compressor RLA plus 100 percent of the second compressor RLA and the sum of the condenser fan FLAs.
- RLA - Rated Load Amps - rated in accordance with UL Standard 1995.
- Local codes may take precedence.
- Control kW includes operational controls only. Does not include evaporator heaters.
- XLRA - Locked Rotor Amps - based on full winding (x-line) start units. YLRA for wye-delta starters is ~1/3 of LRA of x-line units.
- VOLTAGE UTILIZATION RANGE:

Rated Voltage	Utilization Range
230/60/3	208-254
380/60/3	342-418
440/60/3	414-506

- A separate 115/60/1, 20 amp or 220/50/1, 15 amp customer provided power connection is needed to power the evaporator heaters (1640 watts).
- If factory circuit breakers are supplied with the chiller, then these values represent Maximum Overcurrent Protection (MOP).
- When recommended option with circuit breaker, we are providing two circuit breakers (one per circuit) for feeding single point and double point.



Electrical Data

Tab. 19 - Unit electrical data for high efficiency at standard ambient operation

Unit Size	Rated Voltage	# of Power Conns (1)	Unit Wiring				Motor Data						
			MCA (3) Ckt1/Ckt2	Max. fuse HACR Breaker or MOP(11) Ckt1/Ckt2	Rec. Time rec. delay or RDE(4) Ckt1/Ckt2	Qty.	Compressor (Each)			Fans (Each)		Control kW (7)	
						Qty.	RLA (5) Ckt1/Ckt2	XLRA (8) Ckt1/Ckt2	YLRA (8) Ckt1/Ckt2	Qty. Ckt1/Ckt2	kW	FLA	
RTAC 140	230/60/3	1	572	700	700	2	225-225	NA	427-427	10	0.75	4.6	0.83
	380/60/3	1	341	450	400	2	136-136	801-801	260-260	10	0.75	2.7	0.83
	440/60/3	1	282	350	350	2	113-113	652-652	212-212	10	0.75	2.2	0.83
RTAC 155	230/60/3	1	628	800	700	2	265-225	NA	506-427	11	0.75	4.6	0.83
	380/60/3	1	376	500	416	2	161-136	973-801	316-260	11	0.75	2.7	0.83
	440/60/3	1	310	400	350	2	133-113	774-652	252-212	11	0.75	2.2	0.83
RTAC 170	230/60/3	1	675	800	800	2	265-265	NA	506-506	12	0.75	4.6	0.83
	380/60/3	1	404	500	450	2	161-161	973-973	316-316	12	0.75	2.7	0.83
	440/60/3	1	333	450	400	2	133-133	774-774	252-252	12	0.75	2.2	0.83
RTAC 185	230/60/3	1	755	1000	1000	2	324-265	NA	571-506	13	0.75	4.6	0.83
	380/60/3	1	452	600	500	2	196-161	1060-973	345-316	13	0.75	2.7	0.83
	440/60/3	1	372	500	450	2	162-133	878-774	285-252	13	0.75	2.2	0.83
RTAC 200	230/60/3	1	820	1000	1000	2	324-324	NA	571-571	14	0.75	4.6	0.83
	380/60/3	1	490	600	600	2	196-196	1060-1060	345-345	14	0.75	2.7	0.83
	440/60/3	1	404	500	450	2	162-162	878-878	285-285	14	0.75	2.2	0.83
RTAC 225	230/60/3	1	900	1200	1000	2	388-224	NA	691-571	14	0.75	4.6	0.83
	380/60/3	1	539	700	600	2	235-196	1306-1060	424-345	14	0.75	2.7	0.83
	440/60/3	1	444	600	500	2	194-162	1065-878	346-285	14	0.75	2.2	0.83
RTAC 250	230/60/3	1	977	1200	1200	2	388-388	NA	691-691	16	0.75	4.6	0.83
	380/60/3	1	585	800	700	2	235-235	1306-1306	424-424	16	0.75	2.7	0.83
	440/60/3	1	482	600	600	2	194-194	1065-1065	346-346	16	0.75	2.2	0.83
RTAC 275	230/60/3	2	675/444	800/700	800/600	3	265-265/324	NA	506-506/571	12/6	0.75	4.6	1.2
	380/60/3	2	405/266	500/450	450/350	3	161-161/196	973-973/1060	316-316/345	12/6	0.75	2.7	1.2
	440/60/3	2	333/220	450/350	400/300	3	133-133/162	774-774/878	252-252/285	12/6	0.75	2.2	1.2
RTAC 300	230/60/3	2	820/444	1000/700	1000/600	3	324-324/324	NA	571-571/571	14/6	0.75	4.6	1.2
	380/60/3	2	490/266	600/450	600/350	3	196-196/196	1060-1060/1060	345-345/345	14/6	0.75	2.7	1.2
	440/60/3	2	404/220	500/350	450/300	3	162-162/162	878-878/878	285-285/285	14/6	0.75	2.2	1.2

Notes:

- As standard, all units have single point power connection. Optional dual point power connections are available.
- Max Fuse or HACR type breaker = 225 percent of the largest compressor RLA plus 100 percent of the second compressor RLA, plus the sum of the condenser fan FLA per NEC 440-22.
Use FLA per circuit, NOT FLA for the entire unit).
- MCA - Minimum Circuit Ampacity - 125 percent of largest compressor RLA plus 100 percent of the second compressor RLA plus the sum of the condenser fans FLAs per NEC 440-33.
- RECOMMENDED TIME DELAY OR DUAL ELEMENT (RDE) FUSE SIZE: 150 percent of the largest compressor RLA plus 100 percent of the second compressor RLA and the sum of the condenser fan FLAs.
- RLA - Rated Load Amps - rated in accordance with UL Standard 1995.
- Local codes may take precedence.
- Control kW includes operational controls only. Does not include evaporator heaters.
- XLRA - Locked Rotor Amps - based on full winding (x-line) start units. YLRA for wye-delta starters is ~1/3 of LRA of x-line units.
- VOLTAGE UTILIZATION RANGE:

Rated Voltage	Utilization Range
230/60/3	208-254
380/60/3	342-418
440/60/3	414-506

- A separate 115/60/1, 20 amp or 220/50/1, 15 amp customer provided power connection is needed to power the evaporator heaters (1640 watts).
- If factory circuit breakers are supplied with the chiller, then these values represent Maximum Overcurrent Protection (MOP).
- When recommended option with circuit breaker, we are providing two circuit breakers (one per circuit) for feeding single point and double point.



Dimensional Data

Fig. 12 - Unit Dimensions 140 SE 155 SE - 50/60 HZ

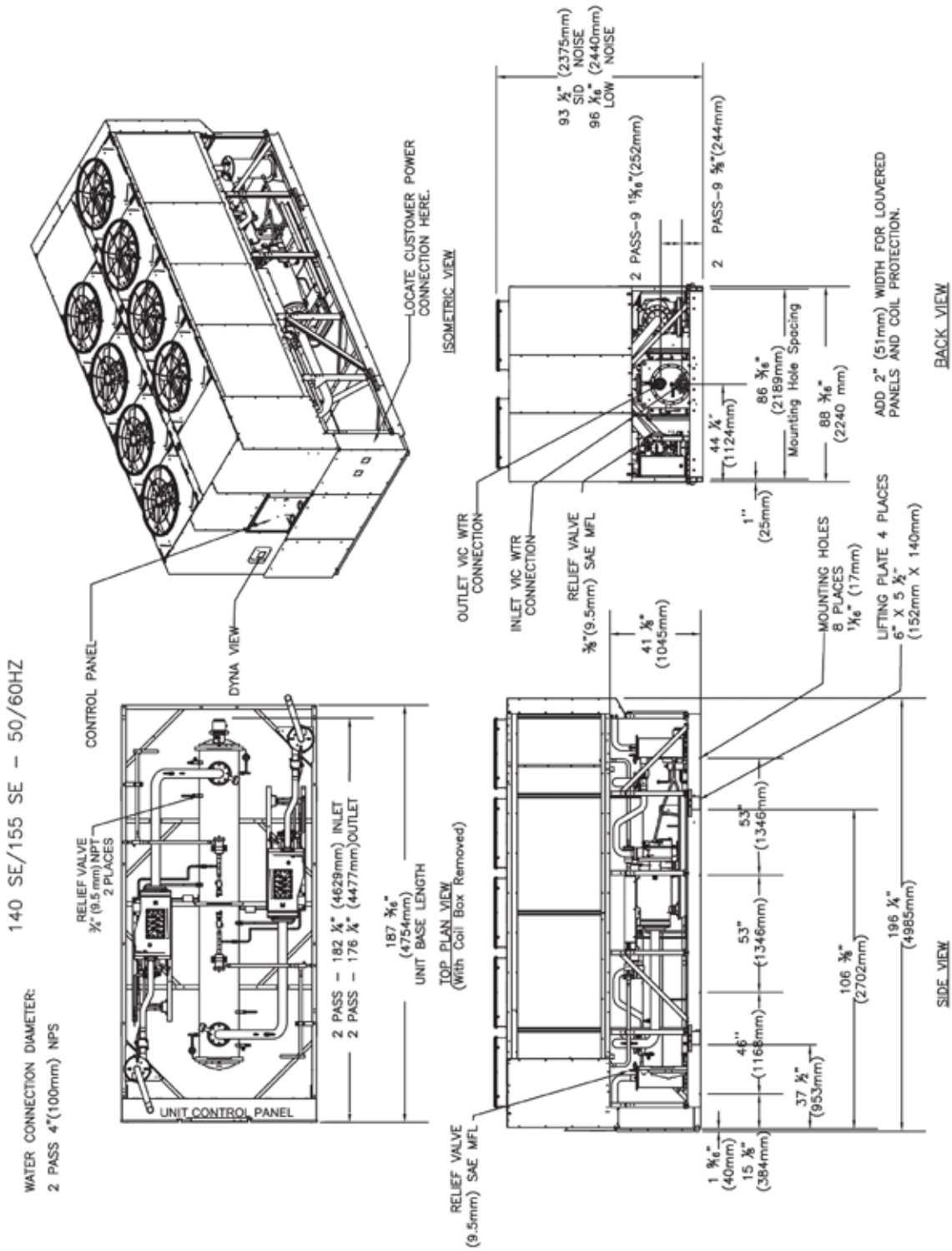



Dimensional Data

Fig. 13 - Unit Dimensions 140 HE 170 SE - 50/60 HZ

140 HE/170SE - 50 / 60HZ

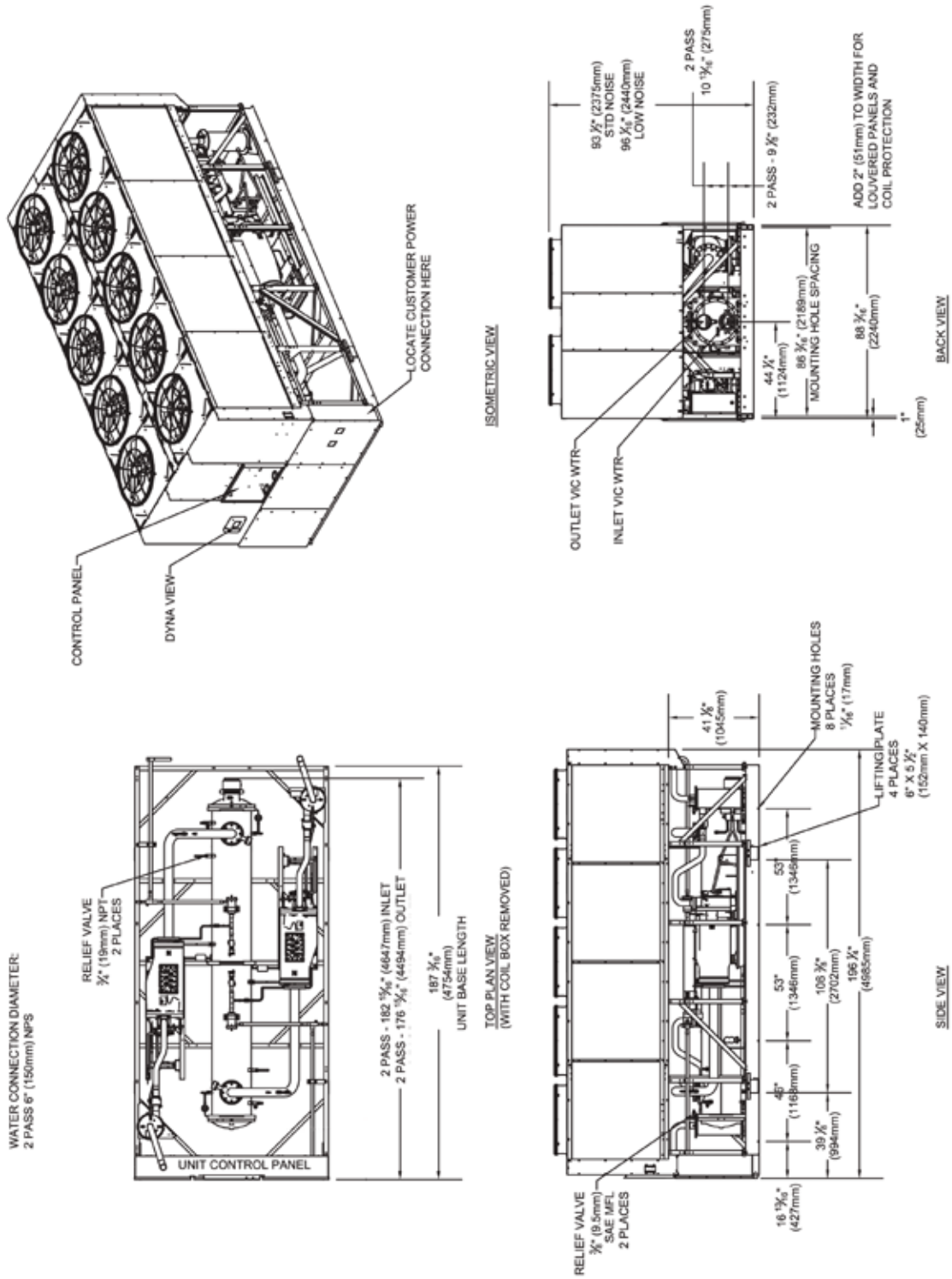



Dimensional Data

Fig. 15 - Unit Dimensions 155-170 XE Ton, 60 Hz and 185-200 HE 225-250 SE Ton, 50 and 60 Hz.

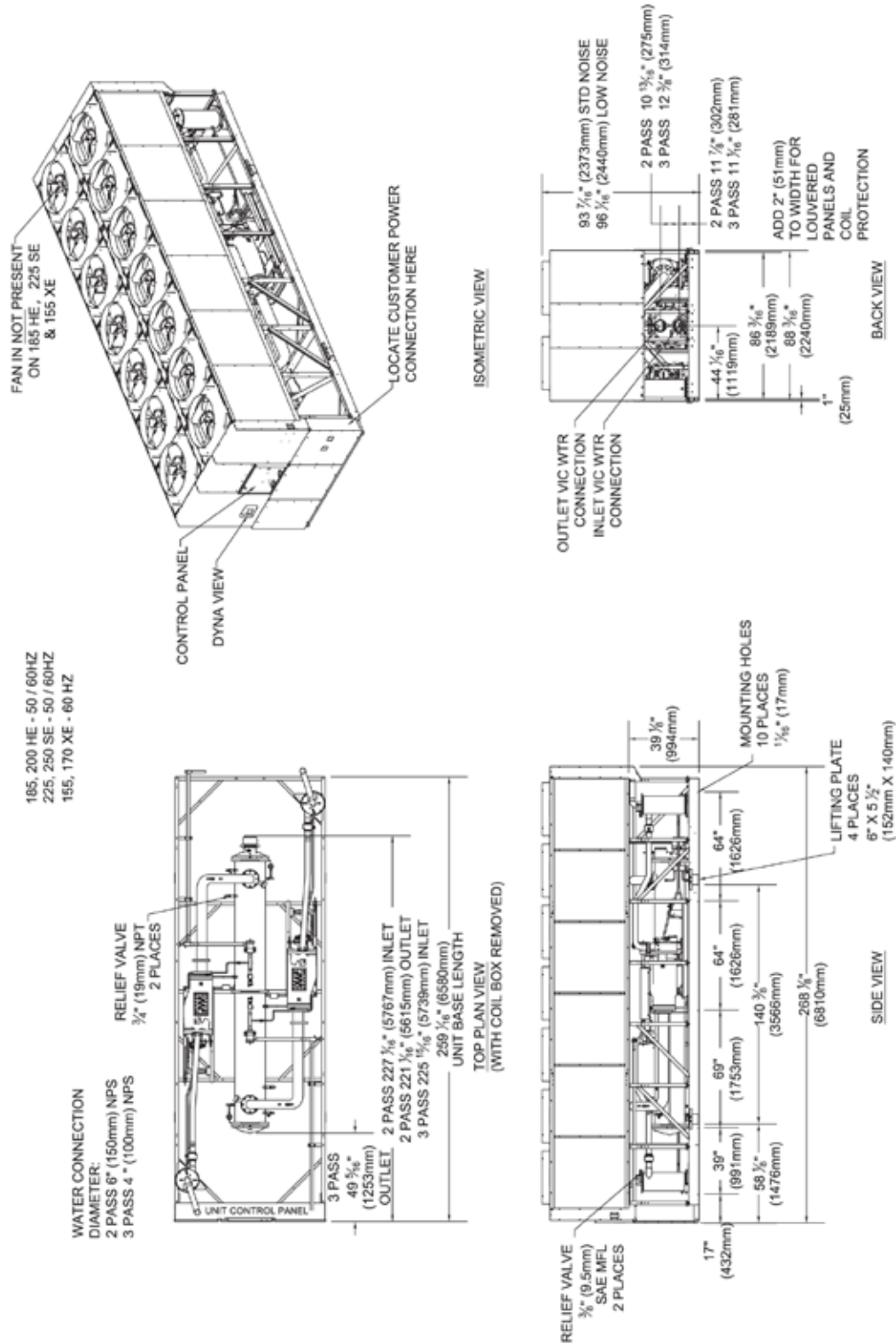



Dimensional Data

Fig. 17 - Unit Dimensions 225-250 HE 185-200 XE Ton, 60 Hz

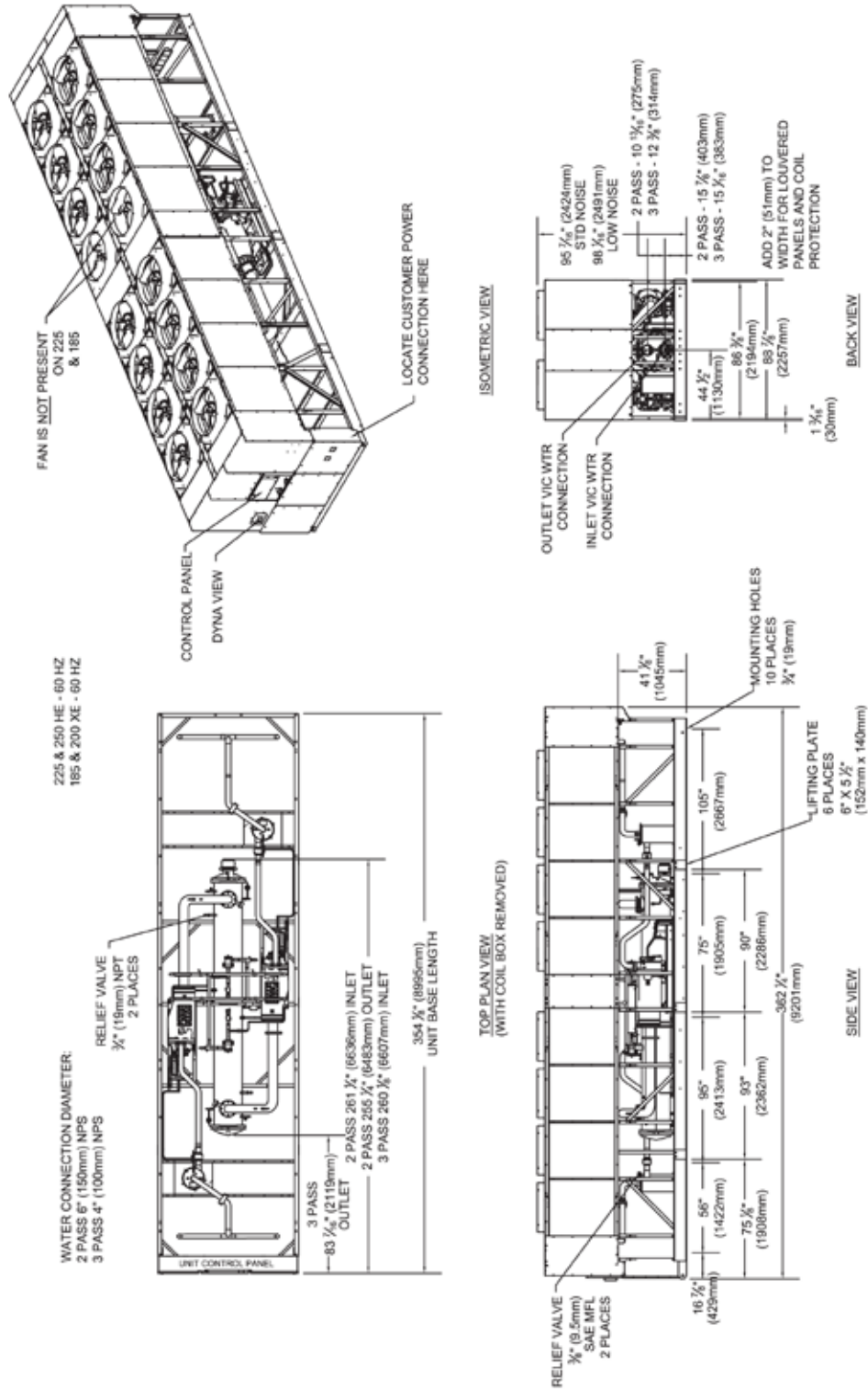



Dimensional Data

Fig. 18 - Unit Dimensions 250 XE Ton 60 Hz; 300 SE 275 HE Ton, 50 60 Hz

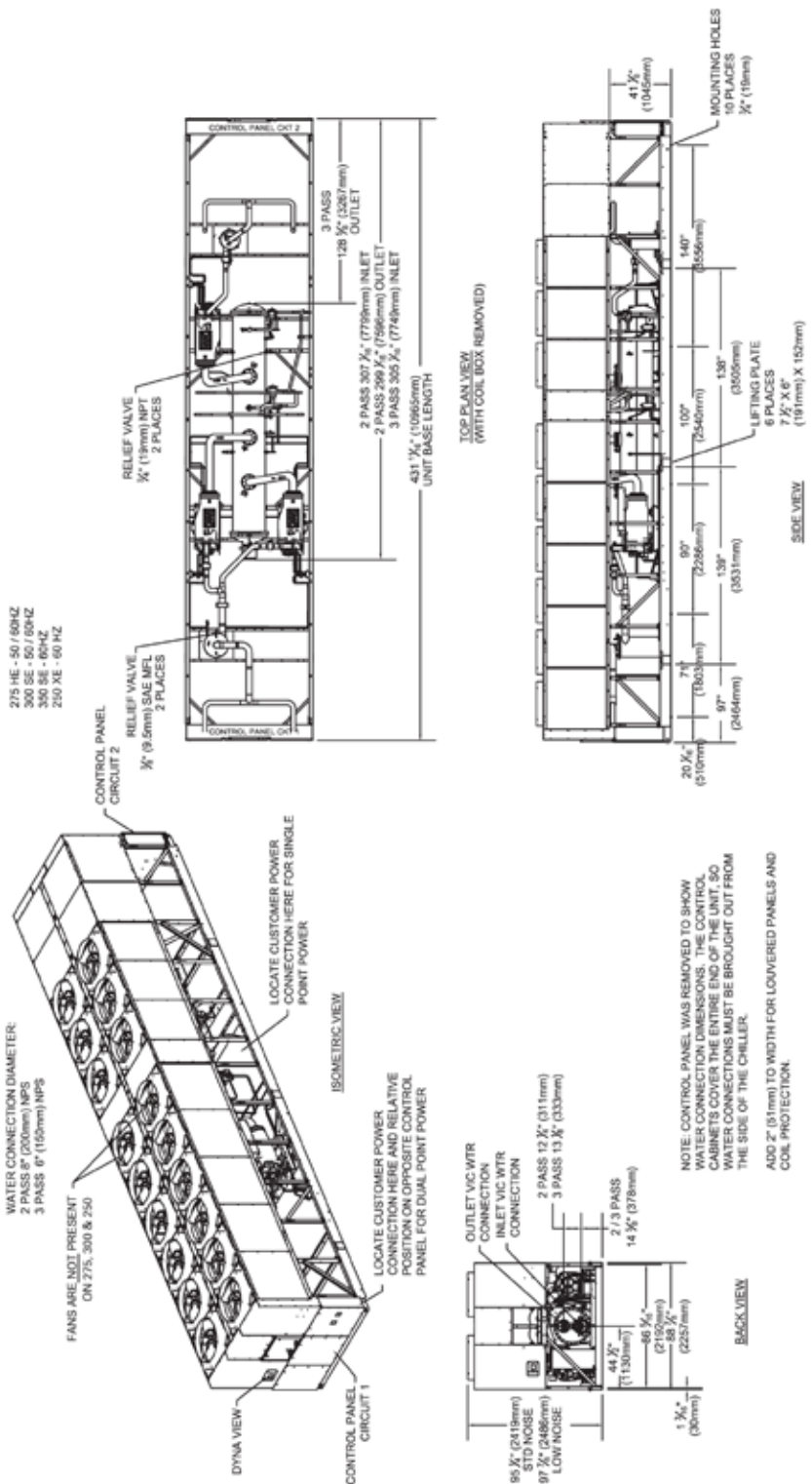



Dimensional Data

Fig. 18 - Unit Dimensions 250 XE Ton 60 Hz; 300 SE 275 HE Ton, 50 60 Hz

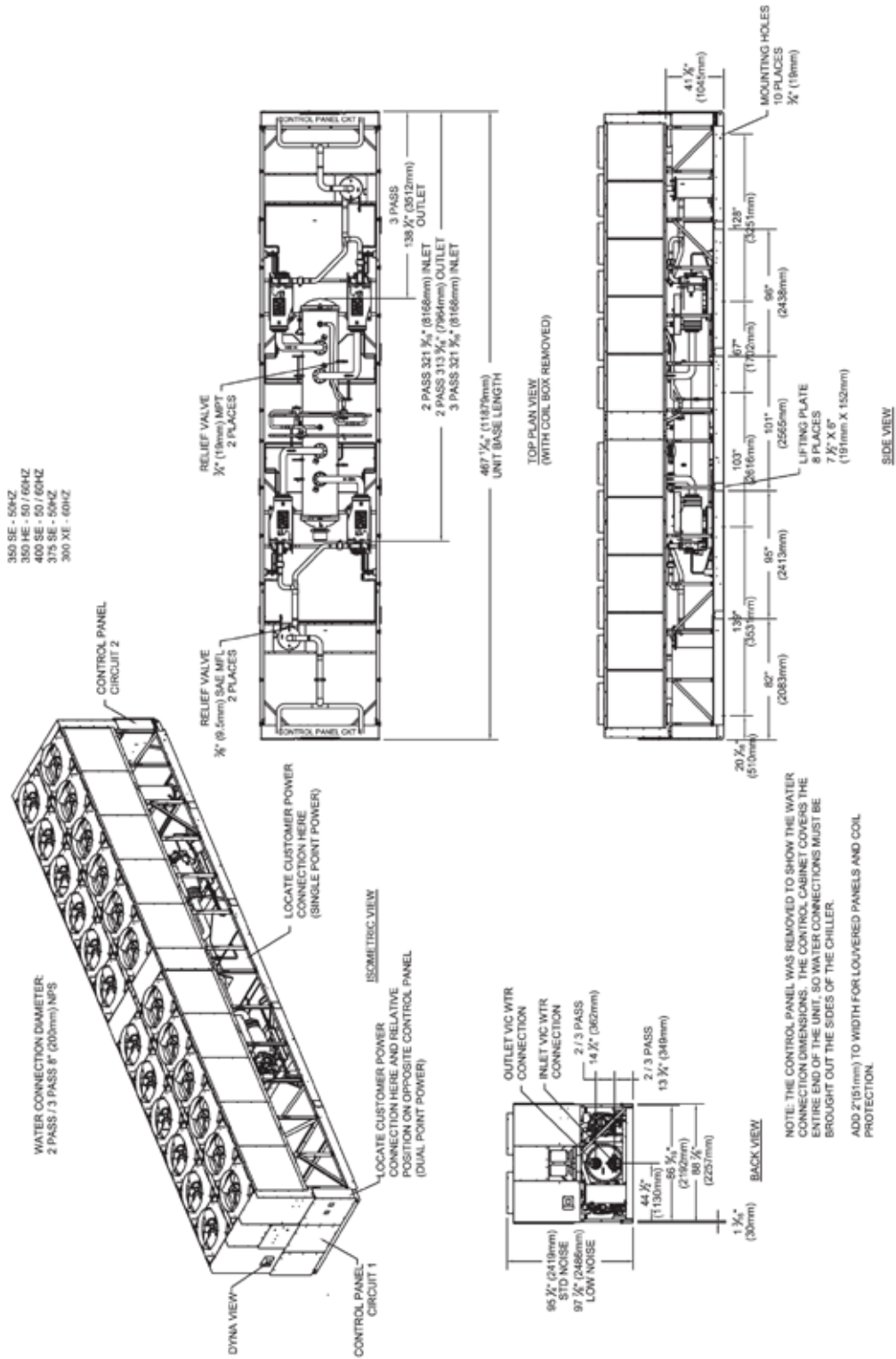



Wiring Diagram

Fig. 19 - Field Layout, 2-Compressor Units

WARNING

HAZARDOUS VOLTAGE!
DISCONNECT ALL ELECTRICAL AND REMOTE DISCONNECTS BEFORE SERVICING.
FAILURE TO DISCONNECT ALL ELECTRICAL POWER BEFORE SERVICING COULD RESULT IN DEATH OR SERIOUS INJURY.

Avertissement

VOLTAGE HASARDEUX!
DECONNECTEZ TOUTES LES SOURCES ELECTRIQUES INCLUANT LES DISJONCTEURS SITUES A DISTANCE AVANT D'EXECUTER L'ENTRETIEN.
FAUTE DE DECONNECTER LA SOURCE ELECTRIQUE AVANT D'EXECUTER L'ENTRETIEN PEUT ENTRAÎNER DES BLESSURES CORPORELLES SEVERES OU LA MORT.

CAUTION

USE COPPER CONDUCTORS ONLY!
UNIT TERMINALS ARE NOT DESIGNED TO ACCEPT OTHER TYPES OF CONDUCTORS.
FAILURE TO DO SO MAY CAUSE DAMAGE TO THE EQUIPMENT.

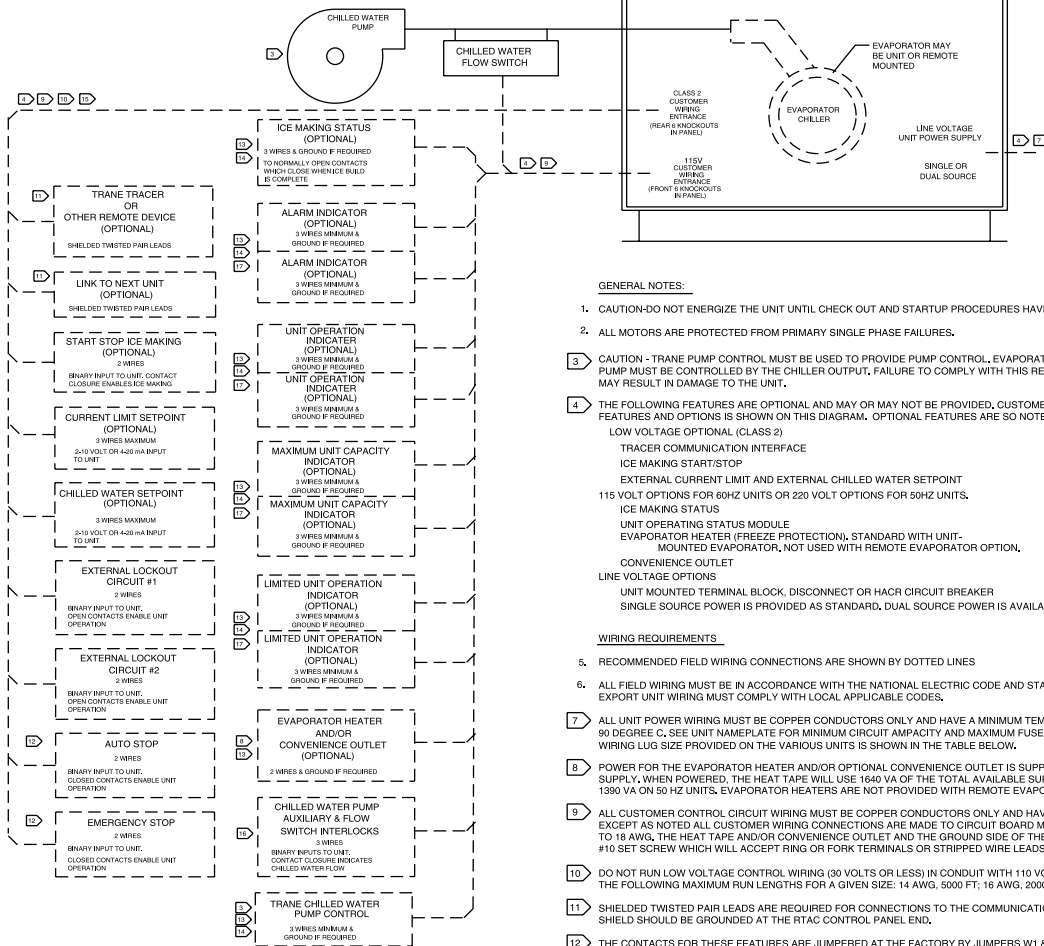

GENERAL NOTES:

- CAUTION-DO NOT ENERGIZE THE UNIT UNTIL CHECK OUT AND STARTUP PROCEDURES HAVE BEEN COMPLETED.
- ALL MOTORS ARE PROTECTED FROM PRIMARY SINGLE PHASE FAILURES.
- CAUTION - TRANE PUMP CONTROL MUST BE USED TO PROVIDE PUMP CONTROL. EVAPORATOR CHILLED WATER PUMP MUST BE CONTROLLED BY THE CHILLER OUTPUT. FAILURE TO COMPLY WITH THIS REQUIREMENT MAY RESULT IN DAMAGE TO THE UNIT.
- THE FOLLOWING FEATURES ARE OPTIONAL AND MAY OR MAY NOT BE PROVIDED. CUSTOMER PROVIDED WIRING FOR ALL STANDARD FEATURES AND OPTIONS IS SHOWN ON THIS DIAGRAM. OPTIONAL FEATURES ARE SO NOTED.
LOW VOLTAGE OPTIONAL (CLASS 2)
TRACER COMMUNICATION INTERFACE
ICE MAKING START/STOP
EXTERNAL CURRENT LIMIT AND EXTERNAL CHILLED WATER SETPOINT
115 VOLT OPTIONS FOR 60HZ UNITS OR 220 VOLT OPTIONS FOR 50HZ UNITS.
ICE MAKING STATUS
UNIT OPERATING STATUS MODULE
EVAPORATOR HEATER (FREEZE PROTECTION). STANDARD WITH UNIT-MOUNTED EVAPORATOR, NOT USED WITH REMOTE EVAPORATOR OPTION.
CONVENIENCE OUTLET
LINE VOLTAGE OPTIONS
UNIT MOUNTED TERMINAL BLOCK, DISCONNECT OR HACR CIRCUIT BREAKER
SINGLE SOURCE POWER IS PROVIDED AS STANDARD, DUAL SOURCE POWER IS AVAILABLE AS AN OPTION.

WIRING REQUIREMENTS

- RECOMMENDED FIELD WIRING CONNECTIONS ARE SHOWN BY DOTTED LINES
- ALL FIELD WIRING MUST BE IN ACCORDANCE WITH THE NATIONAL ELECTRIC CODE AND STATE AND LOCAL REQUIREMENTS. EXPORT UNIT WIRING MUST COMPLY WITH LOCAL APPLICABLE CODES.
- ALL UNIT POWER WIRING MUST BE COPPER CONDUCTORS ONLY AND HAVE A MINIMUM TEMPERATURE INSULATION RATING OF 90 DEGREE C. SEE UNIT NAMEPLATE FOR MINIMUM CIRCUIT AMPACITY AND MAXIMUM FUSE SIZE REQUIREMENTS. THE POWER WIRING LUG SIZE PROVIDED ON THE VARIOUS UNITS IS SHOWN IN THE TABLE BELOW.
- POWER FOR THE EVAPORATOR HEATER AND/OR OPTIONAL CONVENIENCE OUTLET IS SUPPLIED BY A COMMON CUSTOMER PROVIDED POWER SUPPLY. WHEN POWERED, THE HEAT TAPE WILL USE 1640 VA OF THE TOTAL AVAILABLE SUPPLY ON 60HZ UNITS AND APPROXIMATELY 1390 VA ON 50 HZ UNITS. EVAPORATOR HEATERS ARE NOT PROVIDED WITH REMOTE EVAPORATOR UNITS.
- ALL CUSTOMER CONTROL CIRCUIT WIRING MUST BE COPPER CONDUCTORS ONLY AND HAVE A MINIMUM INSULATION RATING OF 300 VOLTS. EXCEPT AS NOTED ALL CUSTOMER WIRING CONNECTIONS ARE MADE TO CIRCUIT BOARD MOUNTED BOX LUGS WITH A WIRE RANGE OF 14 TO 18 AWG. THE HEAT TAPE AND/OR CONVENIENCE OUTLET AND THE GROUND SIDE OF THE FLOW SWITCH GO TO TERMINAL STRIPS WITH A #10 SET SCREW WHICH WILL ACCEPT RING OR FORK TERMINALS OR STRIPPED WIRE LEADS.
- DO NOT RUN LOW VOLTAGE CONTROL WIRING (30 VOLTS OR LESS) IN CONDUIT WITH 110 VOLT OR HIGHER WIRING. DO NOT EXCEED THE FOLLOWING MAXIMUM RUN LENGTHS FOR A GIVEN SIZE: 14 AWG, 5000 FT; 16 AWG, 2000 FT; 18 AWG, 1000FT
- SHIELDED TWISTED PAIR LEADS ARE REQUIRED FOR CONNECTIONS TO THE COMMUNICATIONS INTERFACE MODULE (1U8), THE SHIELD SHOULD BE GROUNDED AT THE RTAC CONTROL PANEL END.
- THE CONTACTS FOR THESE FEATURES ARE JUMPERED AT THE FACTORY BY JUMPERS W1 & W2 TO ENABLE UNIT OPERATION. IF REMOTE CONTROL IS DESIRED REMOVE THE NOTED JUMPERS AND CONNECT TO THE DESIRED CONTROL CIRCUIT.
- FIELD PROVIDED 115 VOLT 60HZ OR 220 VOLT 50HZ CONTROL POWER SUPPLIES ARE REQUIRED. THE MAX FUSE SIZE FOR EVAPORATOR HEATER AND CONVENIENCE OUTLET IS 20 AMPS ON 115 VOLT 60HZ PRODUCTS AND 15 AMPS ON 220 VOLT 50 HZ PRODUCTS. THE MAX FUSE SIZE FOR ALL OTHER FIELD PROVIDED CIRCUITS IS 15 AMPS. GROUND ALL CUSTOMER PROVIDED POWER SUPPLIES AS REQUIRED BY CODE. GREEN GROUND SCREWS ARE PROVIDED IN UNIT CONTROL PANEL.

CONTACT RATINGS AND REQUIREMENTS

- UNIT PROVIDED DRY CONTACTS FOR THE EVAPORATOR PUMP CONTROL, THE UNIT OPERATING STATUS RELAYS AND ICE MAKING STATUS RELAY ARE RATED FOR 7.2 AMPS RESISTIVE, 2.88 AMPS PILOT DUTY, OR 1/3 HP, 7.2 FLA AT 120 VOLTS 60 HZ. CONTACTS ARE RATED FOR 5 AMPS GENERAL PURPOSE DUTY AT 240 VOLTS.
- CUSTOMER SUPPLIED CONTACTS FOR ALL CLASS 2 CONNECTIONS MUST BE COMPATIBLE WITH DRY CIRCUIT 24 VOLTS DC FOR A 12 MA RESISTIVE LOAD. SILVER OR GOLD PLATED CONTACTS ARE RECOMMENDED.
- FLOW SWITCH & INTERLOCK CONTACTS MUST BE ACCEPTABLE FOR USE IN A 120 VOLT 1 mA CIRCUIT OR A 220 VOLT 2 mA CIRCUIT.
- THE FIELD PROVIDED INDICATORS MAY BE RELAYS, LIGHTS OR AUDIBLE DEVICES. FOUR DUPLICATE INDICATOR FUNCTIONS ARE SHOWN. THE DUPLICATE FUNCTIONS MAY BE CONNECTED TO EITHER OR BOTH OF THE NORMALLY OPEN OR NORMALLY CLOSED RELAY CONTACTS OF EACH OF THE 4 SPDT RELAYS ON THE OPTIONAL UNIT OPERATING STATUS MODULE.
THE FUNCTIONS OF THE OPERATING STATUS MODULE RELAYS ARE PROGRAMMABLE. SEE IOM FOR DETAILS. DEFAULT FUNCTIONS ARE SHOWN.
THE NORMALLY OPEN CONTACTS ON EACH RELAY OPERATE AS FOLLOWS:
CONTACTS TO THE ALARM INDICATOR CLOSE ON A UNIT MALFUNCTION.
CONTACTS TO THE UNIT OPERATION INDICATOR CLOSE WHEN ANY COMPRESSOR IS RUNNING.
CONTACTS TO THE MAX UNIT CAPACITY INDICATOR CLOSE WHEN ALL UNIT COMPRESSORS ARE FULLY LOADED.
CONTACTS TO THE LIMITED UNIT OPERATION INDICATOR CLOSE IF NORMAL UNIT OPERATION IS RESTRICTED BY SOME OPERATING PARAMETER.



Wiring Diagram

Field Wiring Notes, 2-Compressor Units

GENERAL NOTES:

1. CAUTION-DO NOT ENERGIZE THE UNIT UNTIL CHECK OUT AND STARTUP PROCEDURES HAVE BEEN COMPLETED.
2. ALL MOTORS ARE PROTECTED FROM PRIMARY SINGLE PHASE FAILURES.
3. CAUTION-TRANE PUMP CONTROL MUST BE USED TO PROVIDE PUMP CONTROL. EVAPORATOR CHILLED WATER PUMP MUST BE CONTROLLED BY THE CHILLER OUTPUT. FAILURE TO COMPLY WITH THIS REQUIREMENT MAY RESULT IN DAMAGE TO THE UNIT.
4. THE FOLLOWING FEATURES ARE OPTIONAL AND MAY OR MAY NOT BE PROVIDED. CUSTOMER PROVIDED WIRING FOR ALL STANDARD FEATURES AND OPTIONS IS SHOWN ON THIS DIAGRAM. OPTIONAL FEATURES ARE SO NOTED.
 LOW VOLTAGE OPTIONS (CLASS 2)
 TRACER COMMUNICATION INTERFACE
 ICE MAKING START/STOP
 EXTERNAL CURRENT LIMIT AND EXTERNAL CHILLED WATER SETPOINT
 115 VOLT OPTIONS FOR 60HZ UNITS OR 220 VOLT OPTIONS FOR 50HZ UNITS.
 ICE MAKING STATUS
 UNIT OPERATING STATUS MODULE
 EVAPORATOR HEATER (FREEZE PROTECTION), STANDARD WITH UNIT-MOUNTED EVAPORATOR, NOT USED WITH REMOTE EVAPORATOR OPTION.
 CONVENIENCE OUTLET
 LINE VOLTAGE OPTIONS
 UNIT MOUNTED TERMINAL BLOCK, DISCONNECT SWITCH OR HACR CIRCUIT BREAKER (TB, SW OR CB)
19. SINGLE SOURCE POWER IS PROVIDED AS STANDARD. DUAL SOURCE POWER IS AVAILABLE AS AN OPTION. COMPONENTS 1CB2, 1TB2 & 1SW2 ARE PROVIDED ONLY WITH THE DUAL SOURCE POWER OPTION. IF SINGLE SOURCE POWER IS PROVIDED, 1CB1, 1SW1 OR 1TB1 MAY BE MOUNTED VERTICALLY OR HORIZONTALLY. REQUIRED PHASING FOR HORIZONTAL ARRANGEMENT IS SHOWN. SEE INSET A FOR CORRECT PHASING WHEN THE NOTED COMPONENTS ARE MOUNTED VERTICALLY.

WIRING REQUIREMENTS

5. RECOMMENDED FIELD WIRING CONNECTIONS ARE SHOWN BY DOTTED LINES
6. ALL FIELD WIRING MUST BE IN ACCORDANCE WITH THE NATIONAL ELECTRIC CODE AND STATE AND LOCAL REQUIREMENTS. EXPORT UNIT WIRING MUST COMPLY WITH LOCAL APPLICABLE CODES.
7. ALL UNIT POWER WIRING MUST BE COPPER CONDUCTORS ONLY AND HAVE A MINIMUM TEMPERATURE INSULATION RATING OF 90 DEGREE C. SEE UNIT NAMEPLATE FOR MINIMUM CIRCUIT AMPACITY AND MAXIMUM FUSE SIZE REQUIREMENTS. THE POWER WIRING LUG SIZE PROVIDED ON THE VARIOUS UNITS IS SHOWN IN THE ADJACENT TABLE.
8. POWER FOR THE EVAPORATOR HEATER AND/OR OPTIONAL CONVENIENCE OUTLET IS SUPPLIED BY A COMMON CUSTOMER PROVIDED POWER SUPPLY. WHEN POWERED, THE HEAT TAPE WILL USE 1640 VA OF THE TOTAL AVAILABLE SUPPLY ON 60 HZ UNITS AND APPROXIMATELY 1390 VA ON 50 HZ UNITS. EVAPORATOR HEATERS ARE NOT PROVIDED WITH REMOTE EVAPORATOR UNITS.
9. ALL CUSTOMER CONTROL CIRCUIT WIRING MUST BE COPPER CONDUCTORS ONLY AND HAVE A MINIMUM INSULATION RATING OF 300 VOLTS. EXCEPT AS NOTED ALL CUSTOMER WIRING CONNECTIONS ARE MADE TO CIRCUIT BOARD MOUNTED BOX LUGS WITH A WIRE RANGE OF 14 TO 18 AWG. THE HEAT TAPE AND/OR CONVENIENCE OUTLET AND THE GROUND SIDE OF THE FLOW SWITCH GO TO TERMINAL STRIPS WITH A #10 SET SCREW WHICH WILL ACCEPT RING OR FORK TERMINALS OR STRIPPED WIRE LEADS.
10. DO NOT RUN LOW VOLTAGE CONTROL WIRING (30 VOLTS OR LESS) IN CONDUIT WITH 110 VOLT OR HIGHER WIRING. DO NOT EXCEED THE FOLLOWING MAXIMUM RUN LENGTHS FOR A GIVEN SIZE: 14 AWG, 5000 FT; 16 AWG, 2000 FT; 18 AWG, 1000 FT.
11. SHIELDED TWISTED PAIR LEADS ARE REQUIRED FOR CONNECTIONS TO THE COMMUNICATIONS INTERFACE MODULE (1U8). THE SHIELD SHOULD BE GROUNDED AT THE RTAC CONTROL PANEL END.
12. THE CONTACTS FOR THESE FEATURES ARE JUMPED AT THE FACTORY BY JUMPERS W1 & W2 TO ENABLE UNIT OPERATION. IF REMOTE CONTROL IS DESIRED REMOVE THE JUMPERS AND CONNECT TO THE DESIRED CONTROL CIRCUIT.
13. AS SHIPPED THE NORMAL 400 VOLT UNIT CONTROL POWER TRANSFORMERS ARE WIRED ON THE 400 VOLT TAP (H3). TRANSFORMER LEADS 126A & 126B SHOULD BE RECONNECTED TO THE APPROPRIATE TAP FOR THE 380 (H2) OR 415 (H4) VOLT POWER SUPPLIES.
14. GROUND ALL CUSTOMER PROVIDED 115 VOLT POWER SUPPLIES AS REQUIRED BY CODES. GREEN GROUND SCREWS ARE PROVIDED IN THE UNIT CONTROL PANEL.

CONTACT RATINGS AND REQUIREMENTS

15. UNIT PROVIDED DRY CONTACTS FOR THE EVAPORATOR PUMP CONTROL, THE UNIT OPERATING STATUS RELAYS & THE ICE MAKING STATUS RELAY (1U10, 1U12, & 1U13) ARE RATED FOR 7.2 AMPS RESISTIVE, 2.88 AMPS PILOT DUTY, OR 1/3 HP, 7.2 FLA AT 120 VOLTS 60 HZ. CONTACTS ARE RATED FOR 5 AMPS GENERAL PURPOSE DUTY AT 240 VOLTS. THE MAX FUSE SIZE FOR ANY OF THESE CIRCUITS IS 15 AMPS.
16. CUSTOMER SUPPLIED CONTACTS FOR ALL LOW VOLTAGE CONNECTIONS MUST BE COMPATIBLE WITH DRY CIRCUIT 24 VOLTS DC FOR A 12 MA RESISTIVE LOAD. SILVER OR GOLD PLATED CONTACTS ARE RECOMMENDED.
17. FLOW SWITCH AND INTERLOCK CONTACTS MUST BE ACCEPTABLE FOR USE IN A 120 VOLT 1mA CIRCUIT, OR A 220 VOLT 2mA CIRCUIT.
18. THE FIELD PROVIDED INDICATORS MAY BE RELAYS (AS SHOWN), LIGHTS OR AUDIBLE DEVICES. FOUR DUPLICATE FUNCTIONS ARE SHOWN. THE DUPLICATE FUNCTIONS MAY BE CONNECTED TO EITHER OR BOTH OF THE NORMALLY OPEN OR NORMALLY CLOSED RELAY CONTACTS OF EACH OF THE 4 SPDT RELAYS ON THE OPTIONAL UNIT OPERATING STATUS MODULE.

THE FUNCTIONS OF THE OPERATING STATUS MODULE RELAYS ARE PROGRAMABLE. DEFAULT FUNCTIONS ARE SHOWN. SEE IOM FOR DETAILS.

⚠ WARNING

Hazardous Voltage!

Disconnect all electric power, including remote disconnects before servicing. Follow proper lockout/tagout procedures to ensure the power can not be inadvertently energized. Failure to disconnect power before servicing could result in death or serious injury.

CAUTION

Use Copper Conductors Only!

Unit terminals are not designed to accept other types of conductors. Failure to use copper conductors may result in equipment damage.



Wiring Diagram

Field Wiring Notes, 3- & 4-Compressor Units, Dual-Point Power

GENERAL NOTES:

1. CAUTION-DO NOT ENERGIZE THE UNIT UNTIL CHECK OUT AND STARTUP PROCEDURES HAVE BEEN COMPLETED.
2. ALL MOTORS ARE PROTECTED FROM PRIMARY SINGLE PHASE FAILURES.
3. CAUTION-TRANE PUMP CONTROL MUST BE USED TO PROVIDED PUMP CONTROL. EVAPORATOR CHILLED WATER PUMP MUST BE CONTROLLED BY THE CHILLER OUTPUT. FAILURE TO COMPLY WITH THIS REQUIREMENT MAY RESULT IN DAMAGE TO THE UNIT.
4. THE FOLLOWING FEATURES ARE OPTIONAL AND MAY OR MAY NOT BE PROVIDED. CUSTOMER PROVIDED WIRING FOR ALL STANDARD FEATURES AND OPTIONS IS SHOWN ON THIS DIAGRAM. OPTIONAL FEATURES ARE SO NOTED.
 - LOW VOLTAGE OPTIONS (CLASS 2)
 - TRACER COMMUNICATION INTERFACE
 - ICE MAKING START/STOP
 - EXTERNAL CURRENT LIMIT AND EXTERNAL CHILLED WATER SETPOINT
 - 115 VOLT OPTIONS FOR 60HZ, OR 220 VOLT OPTIONS FOR 50HZ.
 - ICE MAKING STATUS
 - UNIT OPERATING STATUS MODULE
 - EVAPORATOR HEATER (FREEZE PROTECTION), STANDARD WITH UNIT MOUNTED EVAPORATOR, NOT USED WITH REMOTE EVAPORATOR OPTION.
 - CONVENIENCE OUTLET OPTION IS AVAILABLE ONLY ON 60HZ UNITS.
19. LINE VOLTAGE OPTIONS
 - SINGLE OR DUAL SOURCE POWER MAY BE SPECIFIED. THIS DRAWING COVERS THE DUAL SOURCE POWER OPTION.
 - WHEN SPECIFIED CUSTOMER POWER WIRING CONNECTIONS ARE MADE TO CIRCUIT 1 (CONTROL PANEL 1) AND CIRCUIT 2 (CONTROL PANEL 2), AVAILABLE OPTIONS IN PANELS 1 & 2 FOR CUSTOMER WIRING TERMINATION INCLUDE TERMINAL BLOCKS, DISCONNECT SWITCHES OR HACR TYPE CIRCUIT BREAKERS, (TB, SW, CB)
 - THE NOTED WIRE TERMINATION DEVICES MAY BE MOUNTED VERTICALLY OR HORIZONTALLY. SEE INSET A FOR CORRECT PHASING WHEN THE DEVICES ARE MOUNTED VERTICALLY.

WIRING REQUIREMENTS

5. RECOMMENDED FIELD WIRING CONNECTIONS ARE SHOWN BY DOTTED LINES.
6. ALL FIELD WIRING MUST BE IN ACCORDANCE WITH THE NATIONAL ELECTRIC CODE AND STATE AND LOCAL REQUIREMENTS. EXPORT UNIT WIRING MUST COMPLY WITH LOCAL APPLICABLE CODES.
7. ALL UNIT POWER WIRING MUST BE COPPER CONDUCTORS ONLY AND HAVE A MINIMUM TEMPERATURE INSULATION RATING OF 90 DEGREE C. SEE UNIT NAMEPLATE FOR MINIMUM CIRCUIT AMPACITY AND MAXIMUM FUSE SIZE REQUIREMENTS. THE POWER WIRING LUG SIZE PROVIDED ON THE VARIOUS UNITS IS SHOWN IN CHART DRAWING 2309-2246.
9. ALL CUSTOMER CONTROL CIRCUIT WIRING MUST BE COPPER CONDUCTORS ONLY AND HAVE A MINIMUM INSULATION RATING OF 300 VOLTS. EXCEPT AS NOTED ALL CUSTOMER WIRING CONNECTIONS ARE MADE TO CIRCUIT BOARD MOUNTED BOX LUGS WITH A WIRE RANGE OF 14 TO 18 AWG. THE HEAT TAPE AND/OR CONVENIENCE OUTLET AND THE GROUND SIDE OF THE FLOW SWITCH GO TO TERMINAL STRIPS WITH A #10 SET SCREW WHICH WILL ACCEPT RING OR FORK TERMINALS OR STRIPPED WIRE LEADS.
10. DO NOT RUN LOW VOLTAGE CONTROL WIRING (30 VOLTS OR LESS) IN CONDUIT WITH 110 VOLT OR HIGHER WIRING. DO NOT EXCEED THE FOLLOWING MAXIMUM RUN LENGTHS FOR A GIVEN SIZE: 14 AWG, 5000 FT; 16 AWG, 2000 FT; 18 AWG, 1000FT
11. SHIELDED TWISTED PAIR LEADS ARE REQUIRED FOR CONNECTIONS TO THE COMMUNICATIONS INTERFACE MODULE (1U8), THE SHIELD SHOULD BE GROUNDED AT THE RTAC CONTROL PANEL END.
12. THE CONTACTS FOR THESE FEATURES ARE JUMPERED AT THE FACTORY BY JUMPERS W1 & W2 TO ENABLE UNIT OPERATION. IF REMOTE CONTROL IS DESIRED REMOVE THE JUMPERS AND CONNECT TO THE DESIRED CONTROL CIRCUIT.
13. AS SHIPPED THE NORMAL 400 VOLT UNIT CONTROL POWER TRANSFORMERS ARE WIRED ON THE 400 VOLT TAP (H3). TRANSFORMER LEADS 126A & 126B SHOULD BE RECONNECTED TO THE APPROPRIATE TAP FOR THE 380 (H2) OR 415 (H4) VOLT POWER SUPPLIES.
14. GROUND ALL CUSTOMER PROVIDED 115 VOLT POWER SUPPLIES AS REQUIRED BY CODES. GREEN GROUND SCREWS ARE PROVIDED IN THE UNIT CONTROL PANEL.

CONTACT RATINGS AND REQUIREMENTS

15. UNIT PROVIDED DRY CONTACTS FOR THE EVAPORATOR PUMP CONTROL, THE UNIT OPERATING STATUS RELAYS & THE ICE MAKING STATUS RELAY (1U10, 1U12, & 1U13) ARE RATED FOR 7.2 AMPS RESISTIVE, 2.88 AMPS PILOT DUTY, OR 1/3 HP, 7.2 FLA AT 120 VOLTS 60 HZ. CONTACTS ARE RATED FOR 5 AMPS GENERAL PURPOSE DUTY AT 240 VOLTS. THE MAX FUSE SIZE FOR ANY OF THESE CIRCUITS IS 15 AMPS.
16. CUSTOMER SUPPLIED CONTACTS FOR ALL LOW VOLTAGE CONNECTIONS MUST BE COMPATIBLE WITH DRY CIRCUIT 24 VOLTS DC FOR A 12 MA RESISTIVE LOAD. SILVER OR GOLD PLATED CONTACTS ARE RECOMMENDED.
17. FLOW SWITCH AND INTERLOCK CONTACTS MUST BE ACCEPTABLE FOR USE IN A 120 VOLT 1mA CIRCUIT, OR A 220 VOLT 2mA CIRCUIT.
18. THE FIELD PROVIDED INDICATORS MAY BE RELAYS (AS SHOWN), LIGHTS OR AUDIBLE DEVICES. FOUR DUPLICATE FUNCTIONS ARE SHOWN. THE DUPLICATE FUNCTIONS MAY BE CONNECTED TO EITHER OR BOTH OF THE NORMALLY OPEN OR NORMALLY CLOSED RELAY CONTACTS OF EACH OF THE 4 SPDT RELAYS ON THE OPTIONAL UNIT OPERATING STATUS MODULE.

THE FUNCTIONS OF THE OPERATING STATUS MODULE RELAYS ARE PROGRAMMABLE. DEFAULT FUNCTIONS ARE SHOWN. SEE IOM FOR DETAILS.

REPLACEMENT FUSE SIZES

FUSE PROTECT FUNCTION	UNIT SIZE	UNIT VOLTAGE	DESIGNATION	VOLTS	CLASS	AMPS
CONDENSER FANS	250 TO 500	ALL	1F1-1F6/1F23-1F28/2F7-2F12/2F23-2F28	600	CLASS	40
CONTROL POWER TRANSFORMER PRIMARY		200/60	1F13,1F14/2F13,2F14			6.25
		230/60			CC	6
		380/60				3.5
		460/60				5
		575/60				4
		400/50				5
CONTROL POWER TRANSFORMER 115 VOLT SEC.		ALL	1F15/2F15			10
CONTROL POWER TRANSFORMER 24 VOLT SEC.		ALL	1F16/2F16			5
INVERTER DRIVE AND OR INVERTER TRANSFORMER PRL		380/60	1F17-1F22/2F17-2F22			9
		460/60,400/50				10
		575/60				6.25

⚠ WARNING

Hazardous Voltage!

Disconnect all electric power, including remote disconnects before servicing. Follow proper lockout/tagout procedures to ensure the power can not be inadvertently energized. Failure to disconnect power before servicing could result in death or serious injury.

CAUTION

Use Copper Conductors Only!

Unit terminals are not designed to accept other types of conductors. Failure to use copper conductors may result in equipment damage.



Wiring Diagram

Fig. 21 - Field Layout, 3- & 4-Compressor Units

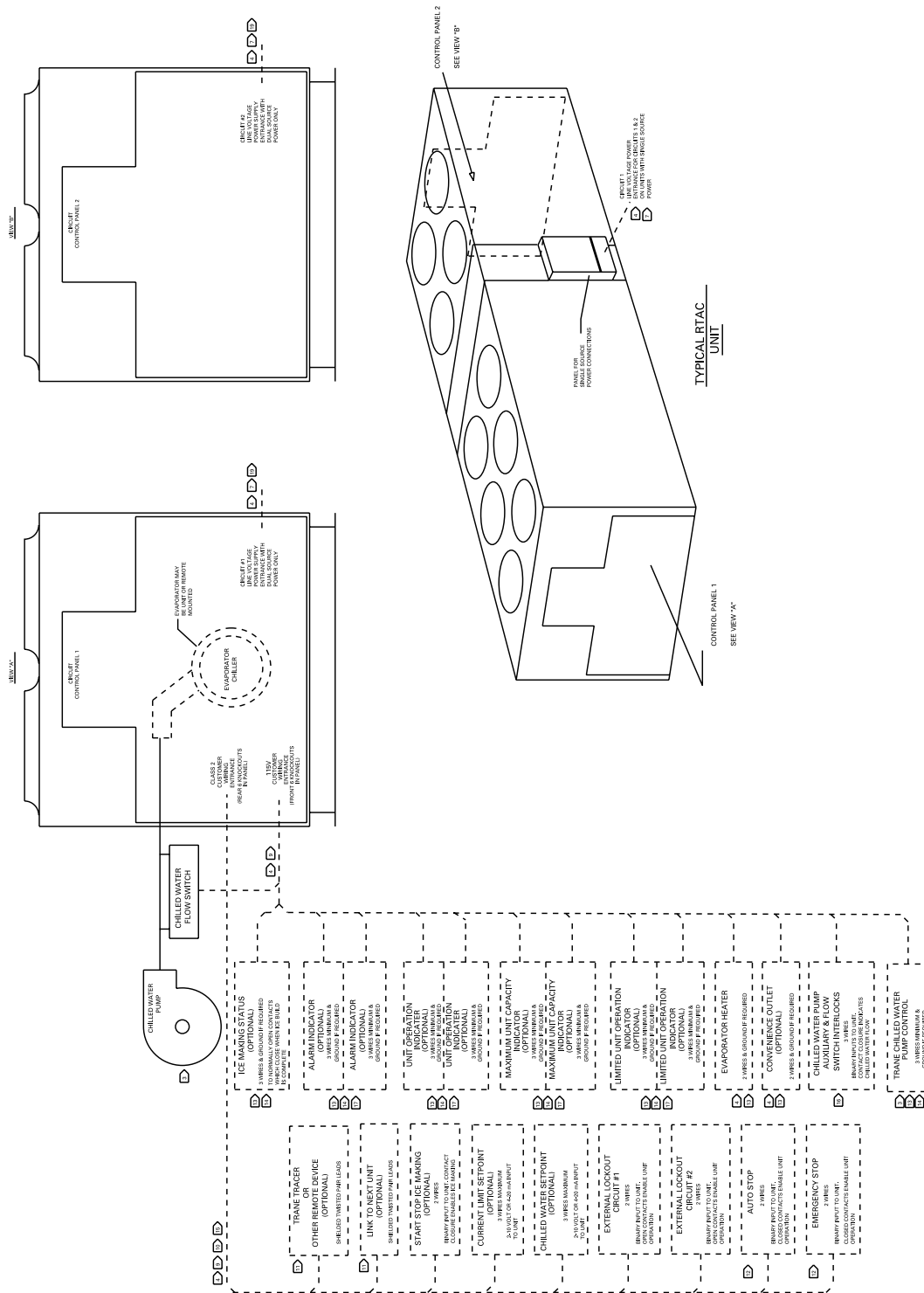



Controls

Standalone Controls

- Human Interfaces

- The Trane air-cooled Model RTAC chiller offers two easy-to-use operator interface panels, the EasyView and the DynaView.
- DynaView is an LCD touchscreen display that is navigated by file tabs. This is an advanced interface that allows the user to access any important information concerning setpoints, active temperatures, modes, electrical data, pressures, and diagnostics.

- Adaptive Safety Controls

- A centralized microcomputer offers a higher level of machine protection. Since the safety controls are smarter, they limit compressor operation to avoid compressor or evaporator failures, thereby minimizing nuisance shutdown. Tracer™ Chiller Controls directly senses the control variables that govern the operation of the chiller: motor current draw, evaporator pressure and condenser pressure. When any one of these variables approaches a limit condition where damage may occur to the unit or shutdown on a safety, Tracer Chiller Controls takes corrective action to avoid shutdown and keep the chiller operating. This happens through combined actions of compressor slide valve modulation, electronic expansion valve modulation and fan staging. Tracer Chiller Controls optimizes total chiller power consumption during normal operating conditions. During abnormal operating conditions, the microprocessor will continue to optimize chiller performance by taking the corrective action necessary to avoid shutdown. This keeps cooling capacity available until the problem can be solved. Whenever possible, the chiller is allowed to perform its function; making chilled water. In addition, microcomputer controls allow for more types of protection such as over and under voltage. Overall, the safety controls help keep the building

Fig. 23 – DynaView operator interface



or process running and out of trouble.

Standalone Controls

- Interface to standalone units is very simple; only a remote auto/stop for scheduling is required for unit operation. Signals from the chilled water pump contactor auxiliary or a flow switch are wired to the chilled waterflow interlock. Signals from a time clock or some other remote device are wired to the external auto/stop input.
- Standard Features
 - • **External Auto/Stop** — A jobsite provided contact closure will turn the unit on and off.
 - • **Chilled Waterflow Interlock** — A jobsite provided contact closure from a chilled water pump contactor or a flow switch is required and will allow unit operation if a load exists. This feature will allow the unit to run in conjunction with the pump system.
 - • **External Interlock** — A jobsite supplied contact opening wired to this input will turn the unit off and require a manual reset of the unit microcomputer. This closure is typically triggered by a jobsite supplied system such as a fire alarm.
 - • **Chilled Water Pump Control** — Unit controls provide an output to control the chilled water pump(s). One contact closure to the chiller is all that is required to initiate the chilled water system. Chilled water pump control by the chiller is a requirement on the Air-Cooled Series R®.

- • Chilled Water Temperature Reset

- Reset can be based on return water temperature or outdoor air temperature.



Controls

Generic Building Automation System Controls

Easy Interface to A Generic Building Management System

Controlling the air-cooled Series R® chiller with building management systems is state-of-the-art, yet simple with either the LonTalk Communications Interface for Chillers (LCI-C) or Generic Building Management System Hardwire Points.

What are LonTalk, Echelon, and LonMark?

LonTalk is a communications protocol developed by the Echelon Corporation. The LonMark association develops control profiles using the LonTalk communication protocol. LonTalk is a unit level communications protocol, unlike BACnet used at the system level.

LonTalk Chiller Controls (LCI-C)

LonTalk Communications Interface for Chillers (LCI-C) provides a generic automation system with the LonMark chiller profile inputs/outputs. In addition to the standard points required by LonMark, Trane provides other commonly used network output variables for greater interoperability with any automation system. Note: LonMark network variable names are in parentheses when different from chiller naming convention.

Chiller Inputs:

- Chiller Enable/Disable
- Chilled Liquid Setpoint (Cool Setpoint)
- Current Limit Setpoint (Capacity Limit)
- Ice Making (Chiller Mode)

Chiller Outputs:

- On/Off
- Active Setpoint
- Average Percent RLA (Actual Capacity)
- Active Current Limit Setpoint
- Leaving Chilled Water Temperature
- Entering Chilled Water Temperature
- Alarm Descriptor
- Chiller Status
- Evaporator Water Pump Request
- Evaporator Refrigerant Temperature
- Evaporator Refrigerant Pressure
- Condenser Refrigerant Temperature
- Condenser Refrigerant Pressure
- Outdoor Air Temperature
- Condenser Air Flow
- Compressor Running
- Maximum Capacity Status

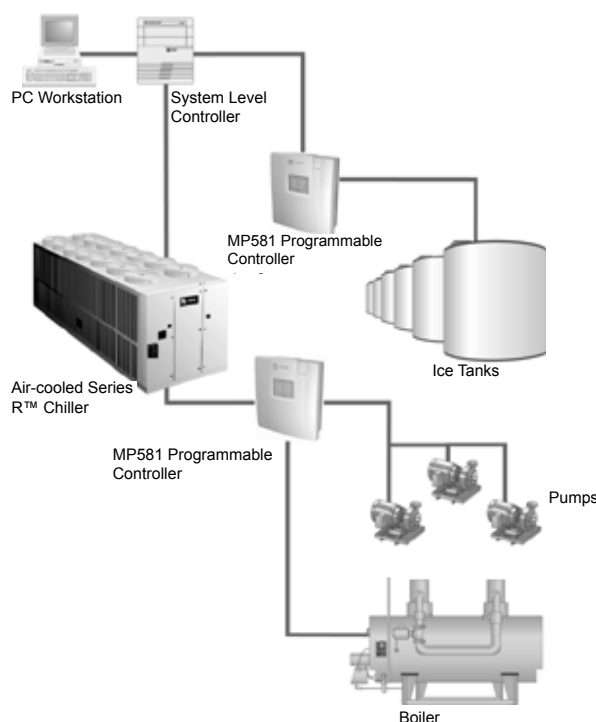

- Current Per Line
- Voltage Per Phase
- Oil Temperature Per Compressor
- Compressor Starts
- Compressor Run Time

Trane controls or another vendor's system can use these points with ease to give the operator a complete picture of how the system is running.

Hardwire Points (GBAS)

GBAS may be achieved via hardware input/output as well.

Chiller hardwire inputs include:

- Chiller enable/disable
- Circuit enable/disable
- External chilled water setpoint
- External current limit setpoint
- Ice making enable

Chiller hardwire outputs include:

- Compressor running indication
- Alarm indication (Ckt1/Ckt 2)
- Maximum capacity
- Ice making status

External Chilled Water Setpoint

Allows the external setting independent

of the front panel setpoint by one of two means:

- a) 2-10 VDC input
- b) 4-20 mA input

External Current Limit Setpoint

Allows the external setting independent of the front panel setpoint by one of two means:

- c) 2-10 VDC input
- b) 4-20 mA input

Alarm Indication Contacts

The unit provides three single-pole/double-throw contact closures to indicate:

- a) Compressor on/off status
- b) Compressor running at maximum capacity
- c) Failure has occurred (Ckt 1/Ckt 2)

These contact closures may be used to trigger jobsite supplied alarm lights or alarm bells.

Ice Making Control

Provides interface with ice making control systems.



Controls

Trane Integrated Comfort System Controls

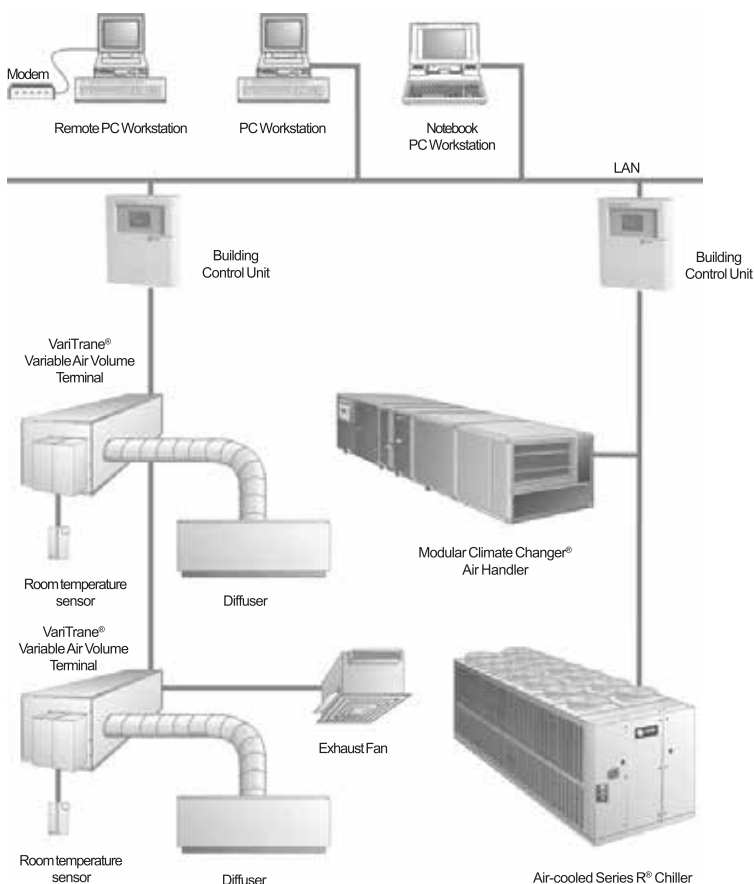

microcomputer can be read off the Tracer system display. In addition, all the powerful diagnostic information can be read back at the Tracer system. Best of all, this powerful capability comes over a single twisted pair of wires! Air-cooled Series R® chillers can interface with many different external control systems, from simple stand-alone units to ice making systems. Each unit requires a single-source, three-phase power supply and a single-phase 115V/60Hz, [220V/50Hz] power supply. The added power supply powers the evaporator heaters.

A single twisted pair of wires tied directly between the air-cooled Series R™ chiller and a Tracer™ Summit system provides control, monitoring and diagnostic capabilities. Control functions include auto/stop, adjustment of leaving water temperature setpoint, compressor operation lockout for kW demand limiting and control of ice making mode. The Tracer system reads monitoring information such as entering and leaving evaporator water temperatures and outdoor air temperature. Over 60 individual diagnostic codes can be read by the Tracer system. In addition, the Tracer system can provide sequencing control for up to 25 units on the same chilled water loop. Pump sequencing control can be provided from the Tracer system. Tracer ICS is not available in conjunction with the remote display or the external setpoint capability.

Required Options

Tracer Interface.

External Trane Devices Required

Tracer Summit™, Tracer 100 System or Tracer Chiller Plant Control.

Additional Features That May Be Used

Ice Making Control.

Tracer Summit controls — Interface With The Trane Integrated Comfort System (ICS)

Trane Chiller Plant Control

The Tracer Summit Chiller Plant Building Management System with Chiller Plant Control provides building automation and energy management functions through stand-alone control. The Chiller Plant Control is capable of monitoring and controlling your entire chiller plant system.

Application software available:

- Time-of-day scheduling
- Demand limiting
- Chiller sequencing
- Process control language
- Boolean processing
- Zone control
- Reports and logs
- Custom messages

- Run time and maintenance
- Trend log
- PID control loops

And of course, the Trane Chiller Plant Control can be used on a stand-alone basis or tied into a complete building automation system.

When the air-cooled Series R™ chiller is used in conjunction with a Trane Tracer™ Summit system, the unit can be monitored and controlled from a remote location. The air-cooled Series R® chiller can be controlled to fit into the overall building automation strategy by using time of day scheduling, timed override, demand limiting, and chiller sequencing. A building owner can completely monitor the air-cooled Series R® chiller from the Tracer system, since all of the monitoring information indicated on the unit controller's



Controls

Trane Integrated Comfort System Controls

Ice Making Systems Controls

When the ice making option is ordered, the air-cooled Series R® chiller will have two operating modes, ice making and normal daytime cooling. In the ice making mode, the air-cooled Series R® chiller will operate at full compressor capacity until the return chilled fluid temperature entering the evaporator meets the ice making setpoint. This ice making setpoint is manually adjusted on the unit's microcomputer. Two input signals are required to the air-cooled Series R® chiller for the ice making option. The first is an auto/stop signal for scheduling and the second is required to switch the unit in between the ice making mode and normal daytime operation. The signals are provided by a remote job site building automation device such as a time clock or a manual switch. In addition, the signals may be provided over the twisted wire pair from a Tracer system or LonTalk Communication Interface but will require the communication boards provided with the Ice Making Control Option.

Trane Chiller Plant Automation

Trane's depth of experience in chillers and controls makes us a well-qualified choice for automation of chiller plants using air-cooled Series R® chillers. The chiller plant control capabilities of the Trane Tracer Summit® building automation system are unequalled in the industry. Our chiller plant automation software is fully pre-engineered and tested. It is a standard software application, not custom programming which can prove to be difficult to support, maintain, and modify.

Energy Efficiency

Trane chiller plant automation intelligently sequences starting of chillers to optimize the overall chiller plant energy efficiency. Individual chillers are designated to operate as base, peak, or swing based on capacity

and efficiency. Sophisticated software automatically determines which chiller to run in response to current conditions. The software also automatically rotates individual chiller operation to equalize runtime and wear between chillers.

Trane chiller plant automation enables unique energy-saving strategies. An example is controlling pumps, and chillers from the perspective of overall system energy consumption. The software intelligently evaluates and selects the lowest energy consumption alternative.

Keeping Operators Informed

A crucial part of efficiently running a chiller plant is assuring that the operations staff is instantly aware of what is happening in the plant. Graphics showing schematics of chillers, piping, pumps, and towers clearly depict the chiller plant system, enabling building operators to easily monitor overall conditions. Status screens display both current conditions and upcoming automated control actions to add or subtract chiller capacity. Series R® and other chillers can be monitored and controlled from a remote location.

Tracer Summit features standard report templates listing key operating data for troubleshooting and verifying performance. Reports for each type of Trane chiller and three and six-chiller systems are also standard. Detailed reports showing chiller runtimes aid in planning for preventative maintenance.

Swift Emergency Response

We understand the importance of maintaining chilled water production while protecting your chillers from costly damage. If no water flow is detected to a chiller's piping, the start sequence is aborted to protect the chiller. The next chiller in the sequence is immediately started to maintain cooling.

In the event of a problem, the operator

receives an alarm notification and diagnostic message to aid in quick and accurate troubleshooting. A snapshot report showing system status just prior to an emergency shutdown helps operators determine the cause. If emergency conditions justify an immediate manual shutdown, the operator can override the automatic control.

Easy Documentation for Regulatory Compliance

Comprehensive documentation of refrigerant management practices is now a fact of life. Trane chiller plant automation generates the reports mandated in ASHRAE Guideline 3.

Integrated Comfort™ Capabilities

When integrated with a Tracer Summit building management system performing building control, Trane chiller plant automation coordinates with Tracer Summit applications to optimize the total building operation. With this system option, the full breadth of Trane's HVAC and controls experience are applied to offer solutions to many facility issues. If your project calls for an interface to other systems, Tracer Summit can share data via BACnet™, the ASHRAE open systems protocol.





Mechanical Specifications

General

Units are leak and pressure tested at 390 psig high side, 250 psig low side, then evacuated and charged. All Air-Cooled Series R® Chillers are factory tested prior to shipment. Packaged units ship with a full operating charge of oil and refrigerant. Unit panels, structural elements and control boxes are constructed of galvanized steel and mounted on a welded structural steel base. Unit panels and control boxes are finished with a baked on powder paint, and the structural base with an air dry paint. All paint meets the requirement for outdoor equipment of the US Navy and other federal government agencies.

Evaporator

The evaporator is a tube-in-shell heat exchanger design with internally and externally finned copper tubes roller expanded into the tube sheet. The evaporator is designed, tested and stamped in accordance with ASME for a refrigerant side working pressure of 200 psig. The evaporator is designed for a water side working pressure of 150 psig. Water connections are grooved pipe. Each shell includes a vent, a drain and fittings for temperature control sensors and is insulated with 3/4-inch equal insulation (K=0.26). Evaporator heaters with thermostat are provided to help protect the evaporator from freezing at ambient temperatures down to -20°F [-29°C].

Condenser and Fans

Air-cooled condenser coils have aluminum fins mechanically bonded to internally finned seamless copper tubing. The condenser coil has an integral subcooling circuit. Condensers are factory proof and leak tested at 506 psig. Direct-drive vertical discharge condenser fans are dynamically balanced. Three-phase condenser fan motors with permanently lubricated ball bearings and internal thermal overload protection are provided. Standard units will start and operate between 25 to 115°F [-4 to 46°C] ambient.

Compressor and Lube Oil System

The rotary screw compressor is semi-hermetic, direct drive, 3600 rpm, 60 Hz, [3000 rpm, 50 Hz], with capacity control slide valve, a load/unload valve, rolling element bearings, oil pumping system by differential pressure refrigerant and oil heater. The motor is a suction gas cooled, hermetically sealed, two-pole squirrel cage induction motor. Oil separator and filtration devices are provided separate from the compressor. Check valves in the compressor discharge and lube oil system and a solenoid valve in the lube system are also provided.

Refrigeration Circuits

Each unit has two refrigerant circuits, with one or two rotary screw compressors per circuit. Each refrigerant circuit includes a compressor suction and discharge service valve, liquid line shutoff valve, removable core filter, liquid line sight glass with moisture indicator, charging port and an electronic expansion valve. Fully modulating compressors and electronic expansion valves provide variable capacity modulation over the entire operating range.

Unit Controls

All unit controls are housed in an outdoor rated weathertight enclosure with removable plates to allow for customer connection of power wiring and remote interlocks. All controls, including sensors, are factory mounted and tested prior to shipment. Microcomputer controls provide all control functions including start-up and shut down, leaving chilled water temperature control, compressor and electronic expansion valve modulation, fan sequencing, anti-recycle logic, automatic lead/lag compressor starting and load limiting. The unit control module, utilizing Adaptive Control™ microprocessor, automatically takes action to avoid unit shutdown due to abnormal operating conditions associated with low refrigerant pressure, high condensing pressure and motor current overload. Should the abnormal operating condition continue until a protective limit is violated, the unit will be shut down. Unit protective functions include

loss of chilled water flow, evaporator freezing, loss of refrigerant, low refrigerant pressure, high refrigerant pressure, reverse rotation, compressor starting and running over current, phase loss, phase imbalance, phase reversal, and loss of oil flow. A digital display indicates chilled water setpoint and leaving chilled water temperature as standard. While current limit setpoint, evaporator and condenser refrigerant pressures, and electrical information are an option. Both standard and optional displays can be viewed on the unit without opening any control panel doors. Standard power connections include main three phase power to the compressors, condenser fans and control power transformer and optional connections are available for the 115 volt/60 Hz single phase power for freeze protection on the evaporator heaters.

Starters

Starters are housed in a weathertight enclosure with removable cover plate to allow for customer connection of power wiring. Across-the-line starters are standard on all 380-575/60 and 400/50 volt units. Wye Delta closed transition starters (33 percent of LRA inrush) are optional on 380-575/60 and 400/50 volt units and standard on 200-230/60 Hz volt units. Typically, Trane helical-rotary screw compressors are up to full speed in one second when started across-the-line and have equivalent inrush with similar size reciprocating compressor with part wind starters.

Chilled Water Reset

This provides the control logic and factory installed sensors to reset leaving chilled water temperature. The setpoint can be reset based on ambient temperature or return evaporator water temperature.

Flow Control

This provides the control logic and relays to turn the chilled water flow on and off as the chiller requires for operation and protection. This function is a requirement on the Air-Cooled Series R® Chiller.



Weights

Tab. 20– Aluminum fin unit weights (60 Hz units)

Unit Size	W1	W2	W3	W4	W5	W6	W7	W8	Operating Weight	Shipping Weight	Xcg	Ycg
	lb	lb	lb	lb	lb	lb	lb	lb	lb	lb	in	in
	kg	kg	kg	kg	kg	kg	kg	kg	kg	kg	mm	mm
RTAC 140 STD	2423	2794	2602	2933	NA	NA	NA	NA	10995	10752	88	45
	1099	1267	1180	1330					4987	4877	2235	1143
RTAC 140 HIGH	2426	2800	2610	2943	NA	NA	NA	NA	11057	10780	88	45
	1100	1270	1184	1335					5015	4885	2235	1143
RTAC 155 STD	2427	2796	2608	2937	NA	NA	NA	NA	11034	10769	88	45
	1101	1268	1183	1332					5005	5460	2235	1143
RTAC 155 HIGH	3095	3489	2530	2924	NA	NA	NA	NA	12332	12038	106	45
	1404	1583	1148	1327					5594	4897	2692	1143
RTAC 170 STD	2429	2803	2615	2948	NA	NA	NA	NA	11073	10796	88	45
	1102	1272	1186	1337					5023	5488	2235	1143
RTAC 170 HIGH	3106	3506	2543	2944	NA	NA	NA	NA	12418	12098	106	46
	1409	1590	1153	1335					5633	5621	2692	1168
RTAC 185 STD	3222	3562	2634	2973	NA	NA	NA	NA	12685	12391	106	44
	1462	1616	1195	1349					5754	6304	2692	1118
RTAC 185 HIGH	4037	4117	2990	3581	NA	NA	NA	NA	14214	13897	124	45
	1831	1867	1356	1624					6447	5799	3150	1143
RTAC 200 STD	3260	3756	2796	3212	NA	NA	NA	NA	13104	12784	106	45
	1479	1704	1268	1457					5944	6462	2692	1143
RTAC 200 HIGH	3632	4187	3110	3578	NA	NA	NA	NA	14593	14247	124	45
	1648	1899	1411	1623					6619	6518	3150	1143
RTAC 225 STD	3632	4229	3114	3632	NA	NA	NA	NA	14687	14370	124	45
	1647	1918	1413	1647					6662	7184	3150	1143
RTAC 225 HIGH	2569	2892	2477	2800	2388	2711	NA	NA	16184	15838	166	44
	1165	1312	1124	1270	1083	1230			7341	6580	4216	1118
RTAC 250 STD	3691	4165	3088	3562	NA	NA	NA	NA	14853	14507	124	45
	1674	1889	1401	1616					6737	7243	3150	1143
RTAC 250 HIGH	2601	2897	2512	2808	2427	2723	NA	NA	16314	15968	166	44
	1180	1314	1140	1274	1101	1235			7400	8562	4216	1118
RTAC 275 STD	3345	2936	3351	2942	3356	2947	NA	NA	19536	18876	176	42
	1517	1332	1520	1334	1522	1337			8862	9193	4470	1067
RTAC 275 HIGH	3251	2863	3571	3183	3894	3505	NA	NA	20944	20266	203	42
	1475	1299	1620	1444	1766	1590			9500	9319	5156	1067
RTAC 300 STD	3456	3074	3615	3233	3774	3393	NA	NA	21103	20544	222	42
	1568	1394	1640	1466	1712	1539			9572	10210	5639	1067
RTAC 300 HIGH	2955	2628	2892	2565	2782	2495	2759	2432	22060	22508	222	42
	1340	1192	1312	1163	1262	1132	1251	1103	10006	9730	5639	1067
RTAC 350 STD	3374	2998	3772	3367	4172	3767	NA	NA	21904	21450	205	42
	1530	1360	1711	1527	1892	1709			9936	10797	5207	1067

Notes:

1. Operating weight includes refrigerant and water.
2. Shipping weight includes refrigerant.
3. All weights +/- 3%.

Unit Top (Plan) View

Control Panel	○	○	○	○	○
	2	4	6	8	10
	○	○	○	○	○
	1	3	5	7	9
	○	○	○	○	○

Unit Top (Plan) View

Control Panel #1	○	○	○	○	○
	2	4	6	8	10
	○	○	○	○	○
	1	3	5	7	9
	○	○	○	○	○



Weights

Tab. 21 – Aluminum fin unit weights (50 Hz units)

Unit Size	W1	W2	W3	W4	W5	W6	W7	W8	Operating Weight	Shipping Weight	Xcg	Ycg
	lb	lb	lb	lb	lb	lb	lb	lb	lb	lb	in	in
	kg	kg	kg	kg	kg	kg	kg	kg	kg	kg	mm	mm
RTAC 140 STD	2423	2794	2602	2933	NA	NA	NA	NA	10995	10752	88	45
	1099	1267	1180	1330					4987	4877	2235	1143
RTAC 140 HIGH	2426	2800	2610	2943	NA	NA	NA	NA	11057	10780	88	45
	1100	1270	1184	1335					5015	4885	2235	1143
RTAC 155 STD	2427	2796	2608	2937	NA	NA	NA	NA	11034	10769	88	45
	1101	1268	1183	1332					5005	5460	2235	1143
RTAC 155 HIGH	3095	3489	2530	2924	NA	NA	NA	NA	12332	12038	106	45
	1404	1583	1148	1327					5594	4897	2692	1143
RTAC 170 STD	2429	2803	2615	2948	NA	NA	NA	NA	11073	10796	88	45
	1102	1272	1186	1337					5023	5488	2235	1143
RTAC 170 HIGH	3106	3506	2543	2944	NA	NA	NA	NA	12418	12098	106	46
	1409	1590	1153	1335					5633	5621	2692	1168
RTAC 185 STD	3222	3562	2634	2973	NA	NA	NA	NA	12685	12391	106	44
	1462	1616	1195	1349					5754	6304	2692	1118
RTAC 185 HIGH	4037	4117	2990	3581	NA	NA	NA	NA	14214	13897	124	45
	1831	1867	1356	1624					6447	5799	3150	1143
RTAC 200 STD	3260	3756	2796	3212	NA	NA	NA	NA	13104	12784	106	45
	1479	1704	1268	1457					5944	6462	2692	1143
RTAC 200 HIGH	3632	4187	3110	3578	NA	NA	NA	NA	14593	14247	124	45
	1648	1899	1411	1623					6619	6518	3150	1143
RTAC 225 STD	3632	4229	3114	3632	NA	NA	NA	NA	14687	14370	124	45
	1647	1918	1413	1647					6662	7184	3150	1143
RTAC 225 HIGH	2569	2892	2477	2800	2388	2711	NA	NA	16184	15838	166	44
	1165	1312	1124	1270	1083	1230			7341	6580	4216	1118
RTAC 250 STD	3691	4165	3088	3562	NA	NA	NA	NA	14853	14507	124	45
	1674	1889	1401	1616					6737	7243	3150	1143
RTAC 250 HIGH	2601	2897	2512	2808	2427	2723	NA	NA	16314	15968	166	44
	1180	1314	1140	1274	1101	1235			7400	8562	4216	1118
RTAC 275 STD	3345	2936	3351	2942	3356	2947	NA	NA	19536	18876	176	42
	1517	1332	1520	1334	1522	1337			8862	9193	4470	1067
RTAC 275 HIGH	3251	2863	3571	3183	3894	3505	NA	NA	20944	20266	203	42
	1475	1299	1620	1444	1766	1590			9500	9319	5156	1067
RTAC 300 STD	3456	3074	3615	3233	3774	3393	NA	NA	21103	20544	222	42
	1568	1394	1640	1466	1712	1539			9572	10210	5639	1067
RTAC 300 HIGH	2955	2628	2892	2565	2782	2495	2759	2432	22060	22508	222	42
	1340	1192	1312	1163	1262	1132	1251	1103	10006	9730	5639	1067
RTAC 350 STD	3374	2998	3772	3367	4172	3767	NA	NA	21904	21450	205	42
	1530	1360	1711	1527	1892	1709			9936	10797	5207	1067

Notes:

1. Operating weight includes refrigerant and water.
2. Shipping weight includes refrigerant.
3. All weights +/- 3%.

Unit Top (Plan) View

Control Panel	○	○	○	○	○
	2	4	6	8	10
	○	○	○	○	○
	1	3	5	7	9
	○	○	○	○	○

Unit Top (Plan) View

Control Panel #1	○	○	○	○	○
	2	4	6	8	10
	○	○	○	○	○
	1	3	5	7	9
	○	○	○	○	○



Standard Conversion Table

To convert from:	To:	Multiply By:	To convert from:	To:	Multiply By:
Length			Velocity		
Feet (ft)	meters (m)	0,30481	Feet per minute (ft/min)	meters per second (m/s)	0,00508
Inche (in)	millimeters (mm)	25,4	Feet per second (ft/s)	meters per second (m/s)	0,3048
Area			Energy, Power and Capacity		
Square feet (ft ²)	square meters(m ²)	0,93	British Termal Units (BTU)	Kilowatt (kW)	0,000293
Square inche(in ²)	square millimeters(mm ²)	645,2	British Termal Units (BTU)	Kilocalorie (kcal)	0,252
Volume			Tons (refrig. Effect)	Kilowatt (kW)	3,516
Cubic feet (ft ³)	cubic meters(m ³)	0,0283	Tons (refrig. Effect)	Kilocalorie per hour (kcal/h)	3024
Cubic Inches (in ³)	cubic millimeters (mm ³)	16387	Horsepower (HP)	Kilowatt (kW)	0,7457
Gallons (gal)	litres (L)	3,785			
Gallons (gal)	cubic meters (m ³)	0,003785	Pressão		
Flow			Feet of water (ft.H ₂ O)	Pascal (Pa)	2990
Cubic feet / min (cfm)	cubic meters / second (m ³ /s)	0,000472	Inches os water (in.H ₂ O)	Pascal (Pa)	249
Cubic feet / min (cfm)	cubic meters / hour (m ³ /h)	1,69884	Pounds per square inch (PSI)	Pascal (Pa)	6895
Gallons / min (GPM)	cubic meters / hour (m ³ /h)	0,2271	Pounds per square inch (PSI)	Bar ou kg/cm ²	6,895 x 10 ⁻²
Gallons / min (GPM)	litres / second (L/s)	0,06308	Peso		
			Ounces (oz)	Kilograms (kg)	0,02835
			Pounds (lbs)	Kilograms (kg)	0,4536

Temperature		
°C	C ou F	°F
-40,0	-40	-40
-39,4	-39	-38,2
-38,9	-38	-36,4
-38,3	-37	-34,6
-37,8	-36	-32,8
-37,2	-35	-31
-36,7	-34	-29,2
-36,1	-33	-27,4
-35,6	-32	-25,6
-35,0	-31	-23,8
-34,4	-30	-22
-33,9	-29	-20,2
-33,3	-28	-18,4
-32,8	-27	-16,6
-32,2	-26	-14,8
-31,7	-25	-13
-31,1	-24	-11,2
-30,6	-23	-9,4
-30,0	-22	-7,6
-29,4	-21	-5,8
-28,9	-20	-4
-28,3	-19	-2,2
-27,8	-18	-0,4
-27,2	-17	1,4
-26,7	-16	3,2
-26,1	-15	5
-25,6	-14	6,8
-25,0	-13	8,6
-24,4	-12	10,4
-23,9	-11	12,2
-23,3	-10	14
-22,8	-9	15,8
-22,2	-8	17,6
-21,7	-7	19,4
-21,1	-6	21,2
-20,6	-5	23
-20,0	-4	24,8
-19,4	-3	26,6
-18,9	-2	28,4
-18,3	-1	30,2
-17,8	0	32
-17,2	1	33,8
-16,7	2	35,6
-16,1	3	37,4
-15,6	4	39,2

Temperature		
°C	C ou F	°F
-15,0	5	41
-14,4	6	42,8
-13,9	7	44,6
-13,3	8	46,4
-12,8	9	48,2
-12,2	10	50
-11,7	11	51,8
-11,1	12	53,6
-10,6	13	55,4
-10,0	14	57,2
-9,4	15	59
-8,9	16	60,8
-8,3	17	62,6
-7,8	18	64,4
-7,2	19	66,2
-6,7	20	68
-6,1	21	69,8
-5,6	22	71,6
-5,0	23	73,4
-4,4	24	75,2
-3,9	25	77
-3,3	26	78,8
-2,8	27	80,6
-2,2	28	82,4
-1,7	29	84,2
-1,1	30	86
-0,6	31	87,8
0,0	32	89,6
0,6	33	91,4
1,1	34	93,2
1,7	35	95
2,2	36	96,8
2,8	37	98,6
3,3	38	100,4
3,9	39	102,2
4,4	40	104
5,0	41	105,8
5,6	42	107,6
6,1	43	109,4
6,7	44	111,2
7,2	45	113
7,8	46	114,8
8,3	47	116,6
8,9	48	118,4
9,4	49	120,2

Temperature		
°C	C ou F	°F
10,0	50	122
10,6	51	123,8
11,1	52	125,6
11,7	53	127,4
12,2	54	129,2
12,8	55	131
13,3	56	132,8
13,9	57	134,6
14,4	58	136,4
15,0	59	138,2
15,6	60	140
16,1	61	141,8
16,7	62	143,6
17,2	63	145,4
17,8	64	147,2
18,3	65	149
18,9	66	150,8
19,4	67	152,6
20,0	68	154,4
20,6	69	156,2
21,1	70	158
21,7	71	159,8
22,2	72	161,6
22,8	73	163,4
23,3	74	165,2
23,9	75	167
24,4	76	168,8
25,0	77	170,6
25,6	78	172,4
26,1	79	174,2
26,7	80	176
27,2	81	177,8
27,8	82	179,6
28,3	83	181,4
28,9	84	183,2
29,4	85	185
30,0	86	186,8
30,6	87	188,6
31,1	88	190,4
31,7	89	192,2
32,2	90	194
32,8	91	195,8
33,3	92	197,6
33,9	93	199,4
34,4	94	201,2

Temperature		
°C	C ou F	°F
35,0	95	203
35,6	96	204,8
36,1	97	206,6
36,7	98	208,4
37,2	99	210,2
37,8	100	212
38,3	101	213,8
38,9	102	215,6
39,4	103	217,4
40,0	104	219,2
40,6	105	221
41,1	106	222,8
41,7	107	224,6
42,2	108	226,4
42,8	109	228,2
43,3	110	230
43,9	111	231,8
44,4	112	233,6
45,0	113	235,4
45,6	114	237,2
46,1	115	239
46,7	116	240,8
47,2	117	242,6
47,8	118	244,4
48,3	119	246,2
48,9	120	248
49,4	121	249,8
50,0	122	251,6
50,6	123	253,4
51,1	124	255,2
51,7	125	257
52,2	126	258,8
52,8	127	260,6
53,3	128	262,4
53,9	129	264,2
54,4	130	266
55,0	131	267,8
55,6	132	269,6
56,1	133	271,4
56,7	134	273,2
57,2	135	275
57,8	136	276,8
58,3	137	278,6
58,9	138	280,4
59,4	139	282,2

Temperature		
°C	C ou F	°F
60,0	140	284
60,6	141	285,8
61,1	142	287,6
61,7	143	289,4
62,2	144	291,2
62,8	145	293
63,3	146	294,8
63,9	147	296,6
64,4	148	298,4
65,0	149	300,2
65,6	150	302
66,1	151	303,8
66,7	152	305,6
67,2	153	307,4
67,8	154	309,2
68,3	155	311
68,9	156	312,8
69,4	157	314,6
70,0	158	316,4
70,6	159	318,2
71,1	160	320
71,7	161	321,8
72,2	162	323,6
72,8	163	325,4
73,3	164	327,2
73,9	165	329
74,4	166	330,8
75,0	167	332,6
75,6	168	334,4
76,1	169	336,2
76,7	170	338
77,2	171	339,8
77,8	172	341,6
78,3	173	343,4
78,9	174	345,2
79,4	175	347
80,0	176	348,8
80,6	177	350,6
81,1	178	352,4
81,7	179	354,2
82,2	180	356
82,8	181	357,8
83,3	182	359,6
83,9	183	361,4
84,4	184	363,2



Trane optimizes performance in houses and buildings all over the world. Trane, as an Ingersoll Rand-owned company, is a leader in the creation and development of safe, comfortable and energy-efficient environments, by providing a broad advanced product portfolio on HVAC controls and systems, comprehensive services and replacement parts. For further information, visit www.trane.com.br

Trane pursue a policy of continuous product and product data improvement, while reserving the right to make changes to their designs and specifications without prior notice.

